

MINI MCR-2-V8-FLK 16 - System adapter



2901993

<https://www.phoenixcontact.com/us/products/2901993>

Please be informed that the data shown in this PDF document is generated from our online catalog. Please find the complete data in the user documentation. Our general terms of use for downloads are valid.



Eight MINI Analog Pro signal conditioners and measuring transducers can be connected to a controller with minimal cabling effort and without any errors using system adapters and system cabling.

Product description

Thanks to its innovative plug-in concept, the system adapter offers a time-saving wiring solution. Eight MINI Analog Pro-signal converters are easily connected to a control unit using pluggable system cabling. This leads to a considerable reduction in cabling effort and the risk of wiring errors, compared to PLC-side single-conductor wiring.

Commercial data

Item number	2901993
Packing unit	1 pc
Minimum order quantity	1 pc
Sales key	C404
Product key	DK112Z
GTIN	4046356651813
Weight per piece (including packing)	142 g
Weight per piece (excluding packing)	132.6 g
Customs tariff number	85389099
Country of origin	DE

MINI MCR-2-V8-FLK 16 - System adapter



2901993

<https://www.phoenixcontact.com/us/products/2901993>

Technical data

Product properties

Product type	Interface module
Product family	MINI Analog Pro

Insulation characteristics: GB Standard

Overvoltage category	II
Pollution degree	2

Electrical properties

Rated insulation voltage	50 V _{rms}
Test voltage (Input/output)	0.5 kV

Input data

Signal

Number of inputs	8
Configurable/programmable	no
Max. voltage input signal	30 V
Max. current input signal	4 A (500 mA per ch.)

Output data

Number of outputs	8
Configurable/programmable	no

Connection data

Output

Connection method	IDC/FLK pin strip
Number of positions	16
Pitch	2.54 mm

Ex data

Ex installation (EPL)	Gc
	Div. 2

Dimensions

Width	51.1 mm
Height	104.1 mm
Depth	56.8 mm

Material specifications

Color	gray (RAL 7042)
Housing material	PBT 7 % GF V0

MINI MCR-2-V8-FLK 16 - System adapter



2901993

<https://www.phoenixcontact.com/us/products/2901993>

Environmental and real-life conditions

Ambient conditions

Degree of protection	IP20 (Finger safety)
Ambient temperature (operation)	-40 °C ... 70 °C
Ambient temperature (storage/transport)	-40 °C ... 70 °C
Permissible humidity (operation)	5 % ... 95 %
Permissible humidity (storage/transport)	5 % ... 95 %

Altitude range (≤ 2000 m)

Altitude	≤ 2000 m
Ambient temperature (operation)	-40 °C ... 70 °C
Rated insulation voltage	50 V AC/DC

Altitude range (≤ 3000 m)

Height range	> 2000 m ... 3000 m
Ambient temperature (operation)	-40 °C ... 63 °C
Rated insulation voltage	40 V AC/DC

Altitude range (≤ 4000 m)

Height range	> 3000 m ... 4000 m
Ambient temperature (operation)	-40 °C ... 56 °C
Rated insulation voltage	30 V AC/DC

Altitude range (≤ 5000 m)

Height range	> 4000 m ... 5000 m
Ambient temperature (operation)	-40 °C ... 49 °C
Rated insulation voltage	30 V AC/DC

Approvals

CE

Certificate	CE-compliant
-------------	--------------

ATEX

Identification	⊕ II 3 G Ex ec IIC Gc
Certificate	PxCIF16ATEX2901993U

UKCA Ex (UKEX)

Identification	⊕ II 3 G Ex ec IIC Gc
Certificate	PxCIF22UKEX2901993U

IECEX

Identification	Ex ec IIC Gc
Certificate	IECEX BVS 22.0005U

CCC / China-Ex

Identification	Ex ec IIC Gc
----------------	--------------

MINI MCR-2-V8-FLK 16 - System adapter



2901993

<https://www.phoenixcontact.com/us/products/2901993>

Certificate	2022122308115723
UL, USA/Canada	
Identification	UL 61010 Listed
	Class I, Div. 2, Groups A, B, C, D T5
	Class I, Zone 2, Group IIC T5
EAC Ex	
Identification	Ex nA IIC T4 Gc U
Certificate	BY/112 02.01 TP012 103.01 00081

Standards and regulations

GB Standard

Standards/regulations	GB 3836.1
	GB 3836.3

Mounting

Mounting position	any
-------------------	-----

Notes

Utilization restriction

EMC note	EMC: class A product, see manufacturer's declaration in the download area
----------	---

MINI MCR-2-V8-FLK 16 - System adapter

2901993

<https://www.phoenixcontact.com/us/products/2901993>

Drawings

Block diagram

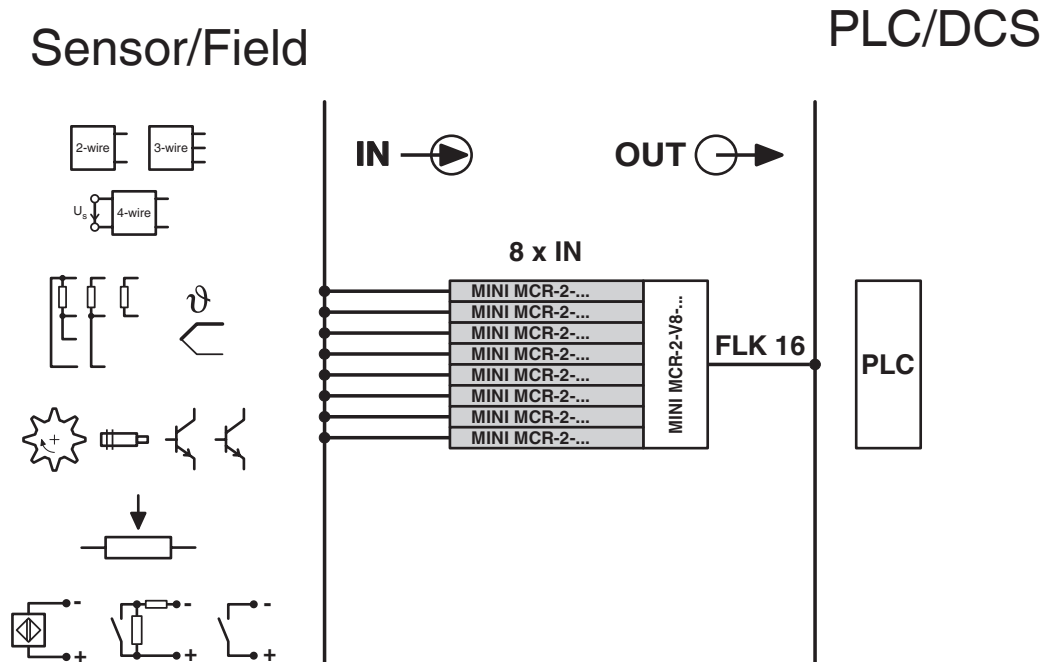

MINI MCR-2-V8-FLK 16 - System adapter



2901993

<https://www.phoenixcontact.com/us/products/2901993>

Approvals

To download certificates, visit the product detail page: <https://www.phoenixcontact.com/us/products/2901993>

 **UL Listed**
Approval ID: E238705

 **cUL Listed**
Approval ID: E238705

 **CCC**
Approval ID: 2022122308115723

 **cUL Listed**
Approval ID: E196811

 **UL Listed**
Approval ID: E196811

 **IECEX**
Approval ID: IECEX BVS 22.0005U

MINI MCR-2-V8-FLK 16 - System adapter



2901993

<https://www.phoenixcontact.com/us/products/2901993>

Classifications

ECLASS

ECLASS-13.0	27141152
ECLASS-15.0	27141152

ETIM

ETIM 10.0	EC002780
-----------	----------

UNSPSC

UNSPSC 21.0	39121400
-------------	----------

MINI MCR-2-V8-FLK 16 - System adapter



2901993

<https://www.phoenixcontact.com/us/products/2901993>

Environmental product compliance

EU RoHS

Fulfills EU RoHS substance requirements	Yes, No exemptions
---	--------------------

China RoHS

Environment friendly use period (EFUP)	EFUP-E
	No hazardous substances above the limits

EU REACH SVHC

REACH candidate substance (CAS No.)	No substance above 0.1 wt%
-------------------------------------	----------------------------

Phoenix Contact 2026 © - all rights reserved
<https://www.phoenixcontact.com>

Phoenix Contact USA
586 Fulling Mill Road
Middletown, PA 17057, United States
(+717) 944-1300
info@phoenixcon.com