

TRK 1,5/ 2 N-FS OG - Transformer terminal block



2700382

<https://www.phoenixcontact.com/us/products/2700382>

Please be informed that the data shown in this PDF document is generated from our online catalog. Please find the complete data in the user documentation. Our general terms of use for downloads are valid.



Transformer terminal block, connection method: Screw/Slip-on connection, length: 28.5 mm, width: 15 mm, height: 19 mm, color: orange

Commercial data

Item number	2700382
Packing unit	50 pc
Minimum order quantity	50 pc
Sales key	AA18
Product key	AARAAB
GTIN	4017918324087
Weight per piece (including packing)	6.236 g
Weight per piece (excluding packing)	6.236 g
Customs tariff number	85369010
Country of origin	GR

TRK 1,5/ 2 N-FS OG - Transformer terminal block



2700382

<https://www.phoenixcontact.com/us/products/2700382>

Technical data

Product properties

Product type	Distributor terminal block
Number of positions	2
Number of connections	6
Number of rows	1

Insulation characteristics

Overvoltage category	III
Degree of pollution	3

Electrical properties

Maximum load current	17.5 A
Rated insulation voltage	800 V
Rated surge voltage	8 kV

Connection data

Maximum load current	17.5 A
Connection method	Screw/Slip-on connection
Screw thread	M3
Tightening torque	0.6 ... 0.8 Nm
Stripping length	9 mm 9 mm
Internal cylindrical gage	A1
Spade connection	2.8 x 0.8 mm
Connection in acc. with standard	IEC / EN
Conductor cross-section rigid	0.5 mm ² ... 1.5 mm ²
Cross section AWG	20 ... 16 (converted acc. to IEC)
Conductor cross-section flexible	0.75 mm ² ... 1.5 mm ²
Conductor cross-section flexible (ferrule without plastic sleeve)	0.5 mm ² ... 1.5 mm ²
Flexible conductor cross-section (ferrule with plastic sleeve)	0.5 mm ² ... 1.5 mm ²
2 conductors with same cross section, rigid	0.5 mm ² ... 1.5 mm ²
2 conductors with same cross section, flexible	0.75 mm ² ... 1.5 mm ²
2 conductors with same cross section, flexible, with ferrule without plastic sleeve	0.5 mm ² ... 1.5 mm ²
2 conductors with the same cross section, flexible, with TWIN ferrule with plastic sleeve	0.5 mm ² ... 1 mm ²
Nominal current	17.5 A
Maximum load current	17.5 A (with 1.5 mm ² conductor cross-section)
Nominal voltage	800 V (voltage data only possible in conjunction with transformer)

Dimensions

TRK 1,5/ 2 N-FS OG - Transformer terminal block



2700382

<https://www.phoenixcontact.com/us/products/2700382>

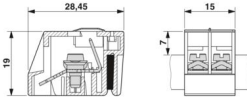
Dimensional drawing	
Width	15 mm
Height	19 mm
Length	28.5 mm

Material specifications

Color (Housing)	orange (RAL 2003)
Flammability rating according to UL 94	V2
Insulating material group	I
Insulating material	PA

Standards and regulations

Connection in acc. with standard	IEC / EN
----------------------------------	----------

Mounting

Mounting type	DIN rail
---------------	----------

Packaging specifications

Type of packaging	packed in cardboard
-------------------	---------------------

TRK 1,5/ 2 N-FS OG - Transformer terminal block



2700382

<https://www.phoenixcontact.com/us/products/2700382>

Drawings

Dimensional drawing

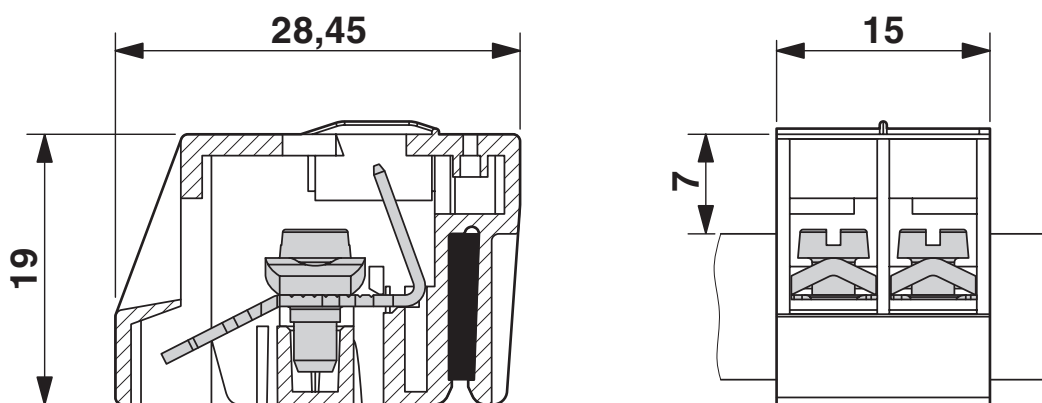

TRK 1,5/ 2 N-FS OG - Transformer terminal block



2700382

<https://www.phoenixcontact.com/us/products/2700382>

Classifications

ECLASS

ECLASS-13.0	27141110
ECLASS-15.0	27141110

UNSPSC

UNSPSC 21.0	39121410
-------------	----------

TRK 1,5/ 2 N-FS OG - Transformer terminal block



2700382

<https://www.phoenixcontact.com/us/products/2700382>

Environmental product compliance

EU RoHS

Fulfills EU RoHS substance requirements	Yes, No exemptions
---	--------------------

China RoHS

Environment friendly use period (EFUP)	EFUP-E
	No hazardous substances above the limits

EU REACH SVHC

REACH candidate substance (CAS No.)	No substance above 0.1 wt%
-------------------------------------	----------------------------

Phoenix Contact 2026 © - all rights reserved
<https://www.phoenixcontact.com>

Phoenix Contact USA
586 Fulling Mill Road
Middletown, PA 17057, United States
(+717) 944-1300
info@phoenixcon.com