

# FLKM 50/32P/PLC - Passive module



2291121

<https://www.phoenixcontact.com/us/products/2291121>

Please be informed that the data shown in this PDF document is generated from our online catalog. Please find the complete data in the user documentation. Our general terms of use for downloads are valid.

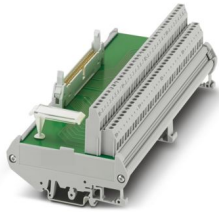

VARIOFACE interface module, for 32 channels, each with an additional terminal block per signal for a common plus potential

## Your advantages

- Byte-by-byte labeling
- Can be used for all digital I/O modules
- Positive connection per signal

## Commercial data

Item number	2291121
Packing unit	1 pc
Minimum order quantity	1 pc
Sales key	C421
Product key	DK2181
GTIN	4017918058265
Weight per piece (including packing)	408 g
Weight per piece (excluding packing)	300.96 g
Customs tariff number	85369010
Country of origin	DE

# FLKM 50/32P/PLC - Passive module



2291121

<https://www.phoenixcontact.com/us/products/2291121>

## Technical data

### Product properties

Product type	Interface module
Product family	VARIOFACE
Number of positions	50
No. of channels	32

### Insulation characteristics: Air clearances and creepage distances

Insulation	Functional insulation
Overvoltage category	II
Pollution degree	2

### Electrical properties

Operating voltage (DC)	≤ 60 V DC
Current (per branch)	≤ 1 A
Current (Voltage supply)	≤ 8 A

### Air clearances and creepage distances

Rated insulation voltage	63 V
Rated surge voltage	0.6 kV (1.2/50 μs)

### Supported controller: SIEMENS S7-1500

Suitable I/O card	6ES7521-1BL00-0AB0
	6ES7522-1BL00-0AB0
	6ES7522-1BL01-0AB0

### Supported controller: SIEMENS S7-400

Suitable I/O card	6ES7421-1BL01-0AA0
	6ES7422-1BL00-0AA0
	6ES7422-7BL00-0AB0

### Supported controller: ALLEN-BRADLEY ControlLogix

Suitable I/O card	1756-IB32
	1756-OB32

### Supported controller: ALLEN-BRADLEY PLC 5

Suitable I/O card	1771 IBN
	1771 OBN

### Supported controller: HONEYWELL Experion PKS C200

Suitable I/O card	TC-IDD 321
	TC-ODD 321

### Supported controller: MITSUBISHI MELSEC L

Suitable I/O card	LX41C4
	LX42C4

# FLKM 50/32P/PLC - Passive module



2291121

<https://www.phoenixcontact.com/us/products/2291121>

	LY41NT1P
	LY42NT1P
	LY41PT1P
	LY42PT1P

## Supported controller: MITSUBISHI MELSEC Q

Suitable I/O card	QX81
	QY81P
	QX41
	QX41-S1
	QX42
	QX42-S1
	QX71
	QX72
	QY41P
	QY42P
	QY71
	QH42P
	QX82
	QX82-S1
QY82P	

## Supported controller: SCHNEIDER ELECTRIC Modicon TSX QUANTUM

Suitable I/O card	DDI 353
	DDI 853
	DAI 453
	DDO 353

## Supported controller: SIEMENS S7-300 / ET 200 M

Suitable I/O card	CPU 313C-2DP
	CPU 314C-2DP
	CPU 314C-2PtP
	6ES7321-1BL00-0AA0
	6ES7322-1BL00-0AA0
	6ES7323-1BL00-0AA0
	CPU 313C
	CPU 313C-2PtP

## Supported controller: GE-FANUC RX3i

Suitable I/O card	IC694MDL754
	IC694MDL660

## Supported controller: SIEMENS ET 200SP HA

Suitable terminal block	6DL1193-6TP00-0BH1
	6DL1193-6TP00-0DH1
	6DL1193-6TP00-0BM1

# FLKM 50/32P/PLC - Passive module



2291121

<https://www.phoenixcontact.com/us/products/2291121>

	6DL1193-6TP00-0DM1
Suitable I/O module	6DL1131-6BL00-0PH1 (Terminal Block H1/M1)
	6DL1132-6BL00-0PH1 (Terminal Block H1/M1)

## Connection data

### Connection 1 (control level)

Connection in acc. with standard	IEC 60603-13
Connection method	IDC/FLK pin strip
Number of connections	1
Number of positions	50
Insertion/withdrawal cycles	> 50
Pitch	2.54 mm

### Connection 2 (field level)

Connection method	Screw connection
Stripping length	7 mm
Screw thread	M3
Number of positions	72
Conductor cross-section rigid	0.2 mm <sup>2</sup> ... 4 mm <sup>2</sup>
Conductor cross-section rigid (2 conductors with same cross section)	0.2 mm <sup>2</sup> ... 1.5 mm <sup>2</sup>
Conductor cross-section flexible	0.2 mm <sup>2</sup> ... 2.5 mm <sup>2</sup>
	0.25 mm <sup>2</sup> ... 1.5 mm <sup>2</sup> (Ferrule without plastic sleeve)
	0.25 mm <sup>2</sup> ... 2.5 mm <sup>2</sup> (Ferrule with plastic sleeve)
Conductor cross-section flexible (2 conductors with same cross section)	0.2 mm <sup>2</sup> ... 1.5 mm <sup>2</sup>
	0.25 mm <sup>2</sup> ... 0.75 mm <sup>2</sup> (Ferrule without plastic sleeve)
	0.5 mm <sup>2</sup> ... 0.5 mm <sup>2</sup> (TWIN ferrule with plastic sleeve)
Conductor cross-section AWG	24 ... 12
Tightening torque	0.5 Nm ... 0.6 Nm
Pitch	5.08 mm

## Signaling

Status display present	no
------------------------	----

## Dimensions

### Item dimensions

Width	190.8 mm
Height	89.6 mm
Depth	65.9 mm

## Material specifications

Color	gray (RAL 7042)
Housing insulation material	PVC

# FLKM 50/32P/PLC - Passive module



2291121

<https://www.phoenixcontact.com/us/products/2291121>

## Environmental and real-life conditions

### Ambient conditions

Degree of protection (Module)	IP00
Degree of protection (Installation location)	≥ IP54
Ambient temperature (operation)	-20 °C ... 50 °C
Ambient temperature (storage/transport)	-20 °C ... 70 °C
Altitude	≤ 2000 m

## Approvals

### UKCA

Certificate	UKCA-compliant
-------------	----------------

## Standards and regulations

### Air clearances and creepage distances

Standards/regulations	EN IEC 60664-1
-----------------------	----------------

## Mounting

Mounting type	DIN rail mounting
Mounting position	any

## Notes

Notes on operation	For proper use, the specifications of the installation directive (see Downloads) must be observed. For applications or use with third-party products, the specifications, and the safety and warning instructions of the respective third-party manufacturer must also be met.
--------------------	--

# FLKM 50/32P/PLC - Passive module



2291121

<https://www.phoenixcontact.com/us/products/2291121>

## Drawings

Circuit diagram

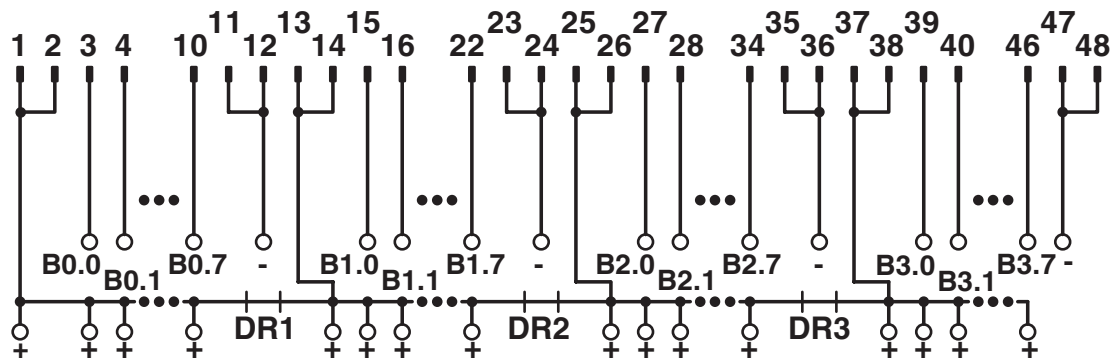

Connection scheme FLKM 50/32P/PLC

# FLKM 50/32P/PLC - Passive module



2291121

<https://www.phoenixcontact.com/us/products/2291121>

## Approvals

To download certificates, visit the product detail page: <https://www.phoenixcontact.com/us/products/2291121>

 <b>cUL Recognized</b> Approval ID: E238705				
	Nominal voltage $U_N$	Nominal current $I_N$	Cross section AWG	Cross section $\text{mm}^2$
keine				
	125 V	2 A	-	-

 <b>UL Recognized</b> Approval ID: E238705				
	Nominal voltage $U_N$	Nominal current $I_N$	Cross section AWG	Cross section $\text{mm}^2$
keine				
	125 V	2 A	-	-

# FLKM 50/32P/PLC - Passive module



2291121

<https://www.phoenixcontact.com/us/products/2291121>

## Classifications

### ECLASS

ECLASS-13.0	27141152
ECLASS-15.0	27141152

### ETIM

ETIM 10.0	EC002780
-----------	----------

### UNSPSC

UNSPSC 21.0	39121400
-------------	----------

# FLKM 50/32P/PLC - Passive module



2291121

<https://www.phoenixcontact.com/us/products/2291121>

## Environmental product compliance

### EU RoHS

Fulfills EU RoHS substance requirements	Yes, No exemptions
---	--------------------

### China RoHS

Environment friendly use period (EFUP)	EFUP-E
	No hazardous substances above the limits

### EU REACH SVHC

REACH candidate substance (CAS No.)	No substance above 0.1 wt%
-------------------------------------	----------------------------

Phoenix Contact 2026 © - all rights reserved  
<https://www.phoenixcontact.com>

Phoenix Contact USA  
586 Fulling Mill Road  
Middletown, PA 17057, United States  
(+717) 944-1300  
[info@phoenixcon.com](mailto:info@phoenixcon.com)