

# MC 1,5/10-LWL 1,5-3,81 - Fiber optic



1841174

<https://www.phoenixcontact.com/us/products/1841174>

Please be informed that the data shown in this PDF document is generated from our online catalog. Please find the complete data in the user documentation. Our general terms of use for downloads are valid.

MINI COMBICON fiber optics, 3.81 mm pitch, 10-pos., separable for other numbers of positions (minimum: 2-pos.), inserts into the back of the MC header, color: transparent, dimension a: 1.5 mm



## Your advantages

- Bending of the light coming from low-profile SMD LEDs by 90°, making it visible from the front
- 10-pos., can be separated for other numbers of positions
- Minimum size 2-pos.

## Commercial data

Item number	1841174
Packing unit	50 pc
Minimum order quantity	50 pc
Sales key	AA08
Product key	AAHZEB
GTIN	4017918111816
Weight per piece (including packing)	3.64 g
Weight per piece (excluding packing)	1.532 g
Customs tariff number	85389099
Country of origin	DE

# MC 1,5/10-LWL 1,5-3,81 - Fiber optic

1841174

<https://www.phoenixcontact.com/us/products/1841174>

## Technical data

### Product properties

Product type	Fiber optic
Product family	MC 1,5/...-LWL
Number of positions	10
Pitch	3.81 mm

### Dimensions

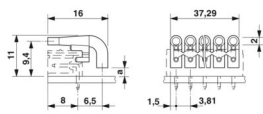
Dimensional drawing	
Pitch	3.81 mm

### Material specifications

Color (Light guide)	transparent
---------------------	-------------

# MC 1,5/10-LWL 1,5-3,81 - Fiber optic



1841174

<https://www.phoenixcontact.com/us/products/1841174>

## Drawings

Dimensional drawing

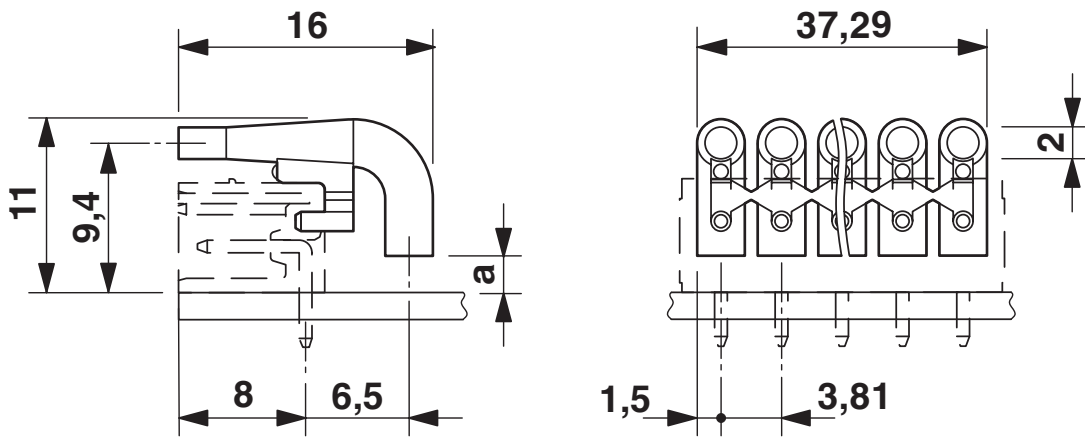

# MC 1,5/10-LWL 1,5-3,81 - Fiber optic



1841174

<https://www.phoenixcontact.com/us/products/1841174>

## Classifications

### ECLASS

ECLASS-13.0	27460404
ECLASS-15.0	27460404

### ETIM

ETIM 10.0	EC002943
-----------	----------

### UNSPSC

UNSPSC 21.0	39121400
-------------	----------

# MC 1,5/10-LWL 1,5-3,81 - Fiber optic



1841174

<https://www.phoenixcontact.com/us/products/1841174>

## Environmental product compliance

### EU RoHS

Fulfills EU RoHS substance requirements	Yes, No exemptions
-----------------------------------------	--------------------

### China RoHS

Environment friendly use period (EFUP)	EFUP-E
	No hazardous substances above the limits

### EU REACH SVHC

REACH candidate substance (CAS No.)	No substance above 0.1 wt%
-------------------------------------	----------------------------

Phoenix Contact 2026 © - all rights reserved  
<https://www.phoenixcontact.com>

Phoenix Contact USA  
586 Fulling Mill Road  
Middletown, PA 17057, United States  
(+717) 944-1300  
[info@phoenixcon.com](mailto:info@phoenixcon.com)