

HC-D 7-SML-57/M1PG11/ALU - Housing



1773284

<https://www.phoenixcontact.com/us/products/1773284>

Please be informed that the data shown in this PDF document is generated from our online catalog. Please find the complete data in the user documentation. Our general terms of use for downloads are valid.



HEAVYCON D7 box mounting base, with single locking latch, height 25.5 mm, with 1 x Pg11 screw connection, with open bottom, zinc

Commercial data

Item number	1773284
Packing unit	1 pc
Note	Made to order (non-returnable)
Sales key	BF55
Product key	AF7AAE
GTIN	4017918134389
Weight per piece (including packing)	85.7 g
Weight per piece (excluding packing)	82.18 g
Customs tariff number	85389099
Country of origin	DE

1773284

<https://www.phoenixcontact.com/us/products/1773284>

Technical data

Product properties

Product type	Housing with locking latch
Housing type	Surface mounting housing
Application	Standard
Type	D7
No. of cable outlets	1
Type of the screw connection	1x Pg11
Shielded	no
Cable outlet	lateral
Pg screw connection	with

Dimensions

Dimensional drawing	
Width	40.5 mm
Height	25.5 mm
Length	24 mm
Wrench size, union nut	18 mm

Material specifications

Material Screw connection	Brass, nickel-plated
Seal material Cable seal	NBR
Housing material	Die-cast zinc
Housing surface material	Powder-coated, gray
Locking latch material	Steel, galvanized

Mechanical properties

Mechanical data

Type of the screw connection	1x Pg11
Locking type	Latch

Cable/line

External cable diameter Cable 1	7.5 mm ... 12.5 mm
---------------------------------	--------------------

Connection data

External cable diameter	7.5 mm ... 12.5 mm
-------------------------	--------------------

Environmental and real-life conditions

HC-D 7-SML-57/M1PG11/ALU - Housing



1773284

<https://www.phoenixcontact.com/us/products/1773284>

Ambient conditions

Degree of protection	IP54
	IP65 (with sealing screw)
Ambient temperature (operation)	-40 °C ... 125 °C

HC-D 7-SML-57/M1PG11/ALU - Housing



1773284

<https://www.phoenixcontact.com/us/products/1773284>

Drawings

Dimensional drawing

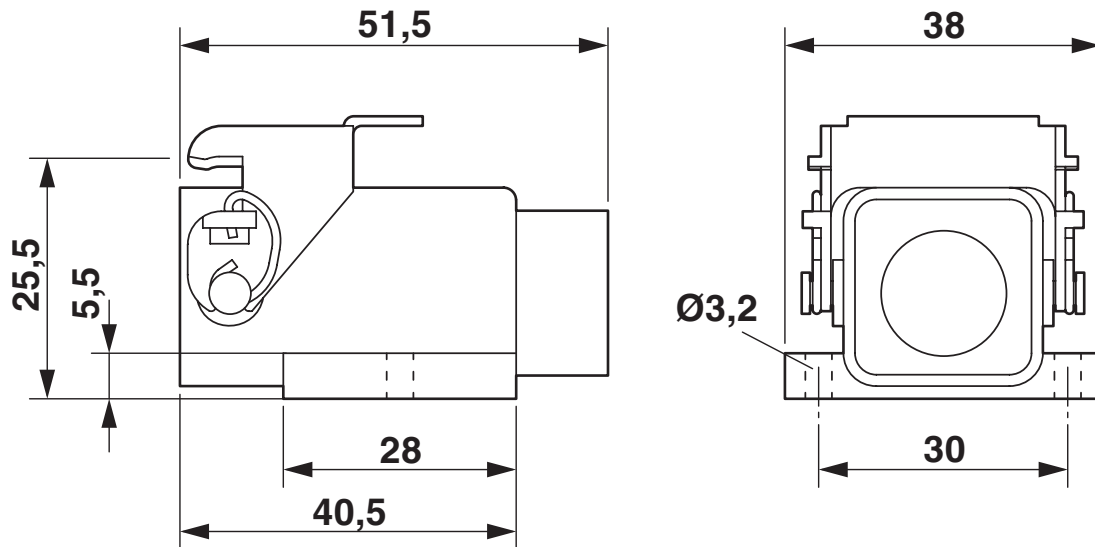

Dimensional drawing

HC-D 7-SML-57/M1PG11/ALU - Housing



1773284

<https://www.phoenixcontact.com/us/products/1773284>

Classifications

ECLASS

ECLASS-13.0	27440202
ECLASS-15.0	27440202

1773284

<https://www.phoenixcontact.com/us/products/1773284>

Environmental product compliance

EU RoHS

Fulfills EU RoHS substance requirements	Yes, No exemptions
-----------------------------------------	--------------------

China RoHS

Environment friendly use period (EFUP)	EFUP-E
	No hazardous substances above the limits

EU REACH SVHC

REACH candidate substance (CAS No.)	No substance above 0.1 wt%
-------------------------------------	----------------------------

Phoenix Contact 2026 © - all rights reserved
<https://www.phoenixcontact.com>

Phoenix Contact USA
586 Fulling Mill Road
Middletown, PA 17057, United States
(+717) 944-1300
info@phoenixcon.com