

PTQ 0,3/ 2-2,5-L THR R32 - PCB terminal block



1703375

<https://www.phoenixcontact.com/us/products/1703375>

Please be informed that the data shown in this PDF document is generated from our online catalog. Please find the complete data in the user documentation. Our general terms of use for downloads are valid.

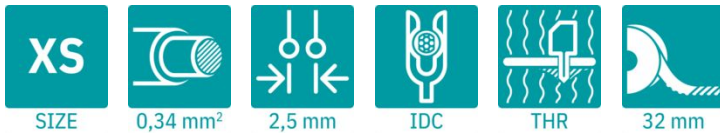

PCB terminal block, nominal current: 4 A, rated voltage (III/2): 160 V, nominal cross section: 0.34 mm², number of potentials: 2, number of rows: 1, number of positions per row: 2, product range: PTQ 0,3/..-THR, pitch: 2.5 mm, connection method: Displacement connection, mounting: THR soldering / wave soldering, conductor/PCB connection direction: 0 °, color: black, Pin layout: Zigzag pinning W, Solder pin [P]: 2 mm, number of solder pins per potential: 1, type of packaging: 32 mm wide tape

Your advantages

- Connection without conductor pretreatment for huge time savings
- Finger-operated QUICKON insulation displacement connection enables repeated conductor connection
- Designed for integration into the SMT soldering process
- Supplied in tape-on-reel packing according to IEC 60286-3 for automated mounting
- Anti-rotation pins reduce the mechanical strain on the soldering spots
- Satisfies CAT5 requirements in accordance with EN 50173 and ISO/IEC 11801

Commercial data

Item number	1703375
Packing unit	250 pc
Minimum order quantity	250 pc
Sales key	AA11
Product key	AAKKA
GTIN	4046356649087
Weight per piece (including packing)	2.704 g
Weight per piece (excluding packing)	2.566 g
Customs tariff number	85369010
Country of origin	PL

PTQ 0,3/ 2-2,5-L THR R32 - PCB terminal block



1703375

<https://www.phoenixcontact.com/us/products/1703375>

Technical data

Product properties

Product type	PCB terminal block
Product family	PTQ 0,3/...-THR
Product line	COMBICON Terminals XS
Type	PC termination block
Number of positions	2
Pitch	2.5 mm
Number of connections	2
Number of rows	1
Number of potentials	2
Pin layout	Zigzag pinning W
Solder pins per potential	1

Electrical properties

Properties

Nominal current I_N	4 A
Nominal voltage U_N	160 V
Rated voltage (III/3)	160 V
Rated surge voltage (III/3)	2.5 kV
Rated voltage (III/2)	160 V
Rated surge voltage (III/2)	2.5 kV
Rated voltage (II/2)	200 V
Rated surge voltage (II/2)	2.5 kV

Connection data

Connection technology

Type	PC termination block
Nominal cross section	0.34 mm ²

Conductor connection

Connection method	Displacement connection
Conductor cross-section rigid	0.14 mm ² ... 0.34 mm ²
Conductor cross-section flexible	0.14 mm ² ... 0.34 mm ²
Conductor cross-section AWG	26 ... 22

Mounting

Mounting type	THR soldering / wave soldering
Pin layout	Zigzag pinning W

Processing notes

Process	Reflow/wave soldering
---------	-----------------------

PTQ 0,3/ 2-2,5-L THR R32 - PCB terminal block



1703375

<https://www.phoenixcontact.com/us/products/1703375>

Moisture Sensitive Level	MSL 1
Classification temperature T _c	260 °C
Solder cycles in the reflow	3

Material specifications

Material data - contact

Note	WEEE/RoHS-compliant, free of whiskers according to IEC 60068-2-82/JEDEC JESD 201
Contact material	Cu alloy
Surface characteristics	hot-dip tin-plated
Metal surface terminal point (top layer)	Tin (3 µm - 5 µm Sn)
Metal surface terminal point (middle layer)	Nickel (1.3 µm - 3 µm Ni)
Metal surface soldering area (top layer)	Tin (3 µm - 5 µm Sn)
Metal surface soldering area (middle layer)	Nickel (1.3 µm - 3 µm Ni)

Material data - housing

Color (Housing)	black (9005)
Insulating material	LCP
Insulating material group	IIIa
CTI according to IEC 60112	175
Flammability rating according to UL 94	V0

Notes

Note on application	The item is qualified for CAT5 Ethernet applications. For this reason, it is suited for use in IoT devices.
---------------------	---

Dimensions

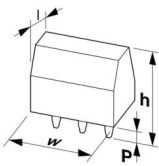
Dimensional drawing	
Pitch	2.5 mm
Width [w]	7 mm
Height [h]	10 mm
Length [l]	17.55 mm
Installed height	8 mm
Solder pin length [P]	2 mm
Pin dimensions	0.9 x 0.4 mm

PCB design

Pin spacing	2.5 mm
Hole diameter	1.1 mm

Mechanical tests

PTQ 0,3/ 2-2,5-L THR R32 - PCB terminal block



1703375

<https://www.phoenixcontact.com/us/products/1703375>

Connection test

Specification	IEC 60998-2-3:2002-12
Result	Test passed

Pull-out test

Specification	IEC 60999-1:1999-11
Conductor cross-section/conductor type/tractive force setpoint/actual value	0.2 mm ² / solid / > 10 N
	0.2 mm ² / flexible / > 10 N

Electrical tests

Temperature-rise test

Specification	IEC 60998-1:2002-12
Requirement temperature-rise test	Increase in temperature ≤ 45 K

Short-time withstand current

Specification	IEC 60998-2-3:2002-12
---------------	-----------------------

Insulation resistance

Specification	IEC 60512-3-1:2002-02
Insulation resistance, neighboring positions	> 5 MΩ

Temperature cycles

Specification	IEC 60998-2-3:2002-12
Result	Test passed

Air clearances and creepage distances |

Specification	IEC 60664-1:2007-04
Insulating material group	IIIa
Comparative tracking index (IEC 60112)	CTI 175
Rated insulation voltage (III/3)	160 V
Rated surge voltage (III/3)	2.5 kV
minimum clearance value - non-homogenous field (III/3)	1.5 mm
minimum creepage distance (III/3)	2.5 mm
Rated insulation voltage (III/2)	160 V
Rated surge voltage (III/2)	2.5 kV
minimum clearance value - non-homogenous field (III/2)	1.5 mm
minimum creepage distance (III/2)	1.6 mm
Rated insulation voltage (II/2)	200 V
Rated surge voltage (II/2)	2.5 kV
minimum clearance value - non-homogenous field (II/2)	1.5 mm
minimum creepage distance (II/2)	2 mm

Environmental and real-life conditions

Shocks

Specification	IEC 60068-2-27:2008-02
---------------	------------------------

PTQ 0,3/ 2-2,5-L THR R32 - PCB terminal block



1703375

<https://www.phoenixcontact.com/us/products/1703375>

Pulse shape	Half-sine
Acceleration	15g
Shock duration	11 ms
Test directions	X-, Y- and Z-axis

Railway application: Shocks

Acceleration	15g
Shock duration	11 ms
Test directions	X-, Y- and Z-axis

Glow-wire test

Specification	IEC 60998-1:2002-12
Time of exposure	5 s

Ambient conditions

Ambient temperature (storage/transport)	-40 °C ... 70 °C
Relative humidity (storage/transport)	30 % ... 70 %
Ambient temperature (assembly)	-5 °C ... 100 °C
Ambient temperature (operation)	-40 °C ... 100 °C (Depending on the current carrying capacity/derating curve)

Packaging specifications

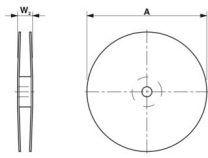
Dimensional drawing	
Type of packaging	32 mm wide tape
[W] tape width	32 mm
[W2] coil overall dimension	≤ 38.4 mm
[A] coil diameter	≤ 330 mm
Outer packaging type	Transparent-Bag

PTQ 0,3/ 2-2,5-L THR R32 - PCB terminal block



1703375

<https://www.phoenixcontact.com/us/products/1703375>

Drawings

Dimensional drawing

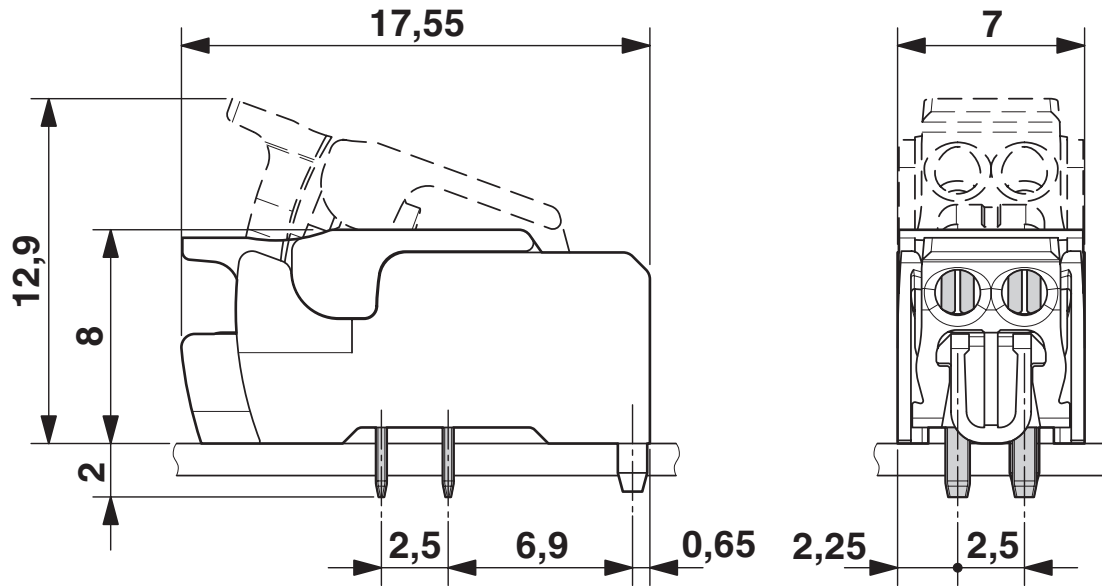

PTQ 0,3/ 2-2,5-L THR R32 - PCB terminal block

1703375

<https://www.phoenixcontact.com/us/products/1703375>



Dimensional drawing

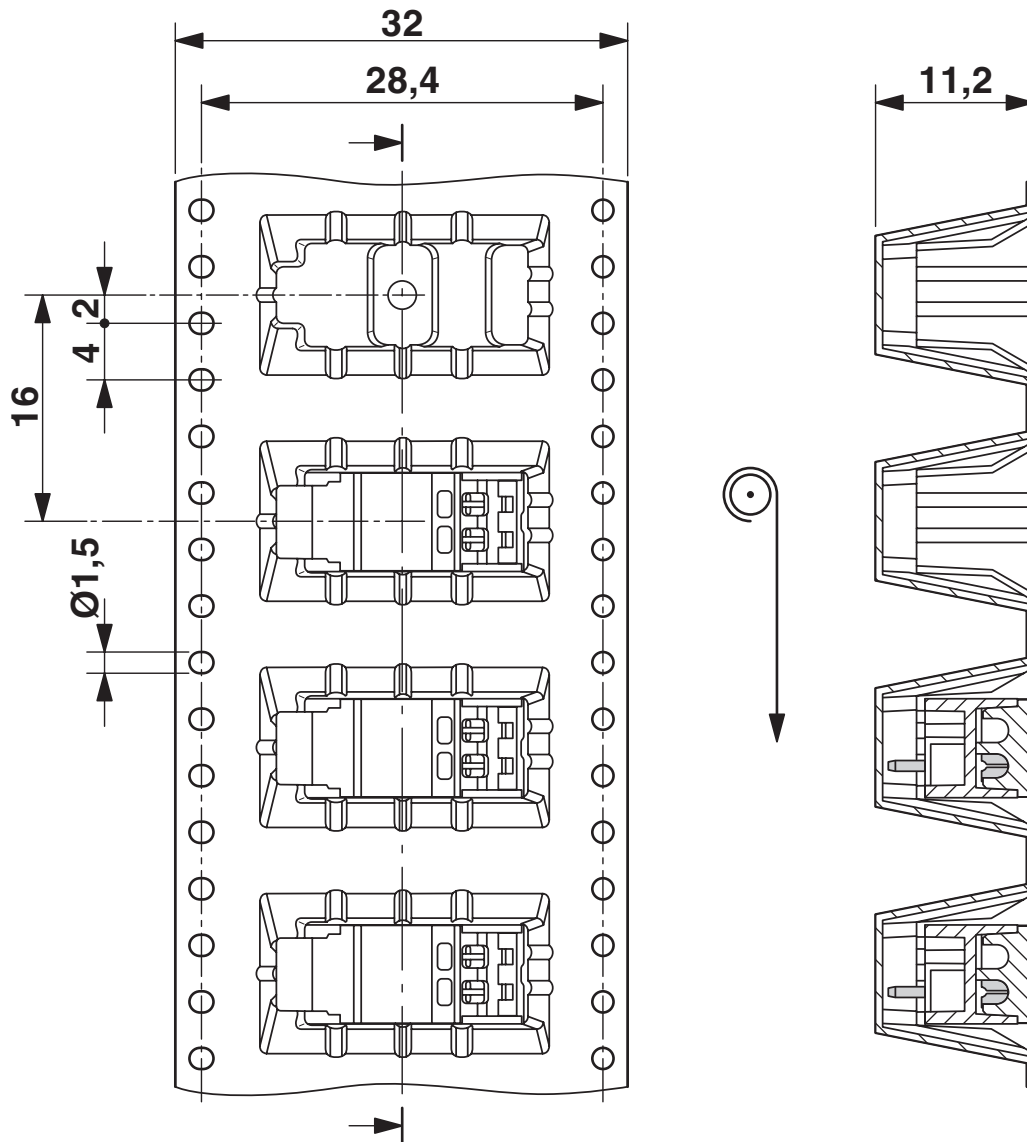

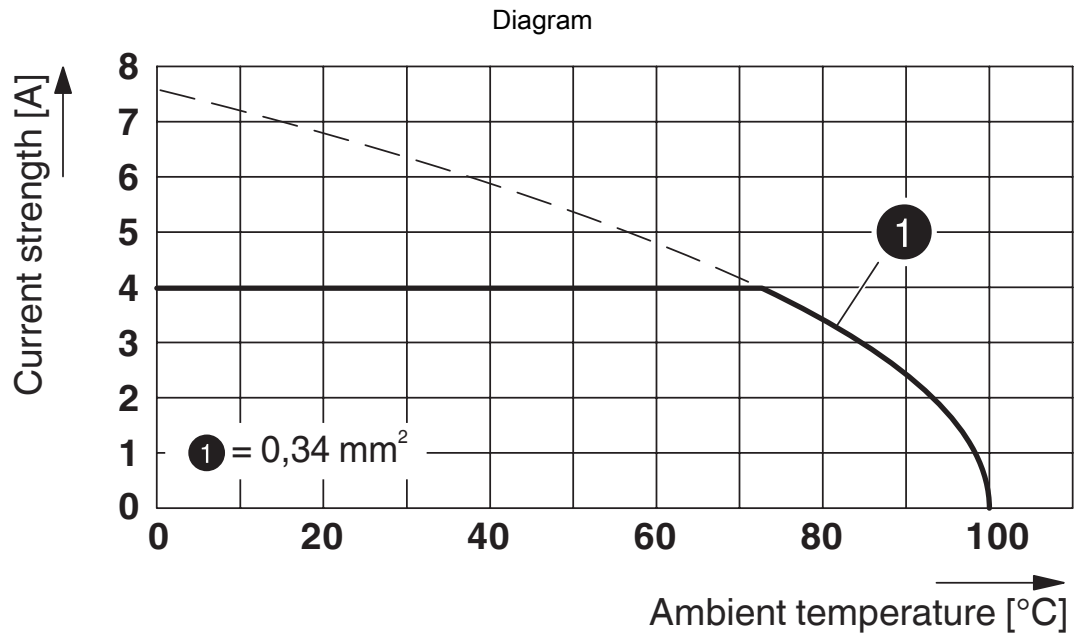

Type: PTQ 0,3/..-2,5(-L) THR R32

PTQ 0,3/ 2-2,5-L THR R32 - PCB terminal block





1703375

<https://www.phoenixcontact.com/us/products/1703375>

Approvals

To download certificates, visit the product detail page: <https://www.phoenixcontact.com/us/products/1703375>

 cULus Recognized Approval ID: E60425-20110108				
	Nominal voltage U_N	Nominal current I_N	Cross section AWG	Cross section mm^2
B	150 V	2 A	24	-

 VDE report with production monitoring Approval ID: 40034315				
	Nominal voltage U_N	Nominal current I_N	Cross section AWG	Cross section mm^2
keine	130 V	4 A	-	- 0.2

PTQ 0,3/ 2-2,5-L THR R32 - PCB terminal block



1703375

<https://www.phoenixcontact.com/us/products/1703375>

Classifications

ECLASS

ECLASS-13.0	27460101
ECLASS-15.0	27460101

ETIM

ETIM 10.0	EC002643
-----------	----------

UNSPSC

UNSPSC 21.0	39121400
-------------	----------

PTQ 0,3/ 2-2,5-L THR R32 - PCB terminal block



1703375

<https://www.phoenixcontact.com/us/products/1703375>

Environmental product compliance

EU RoHS

Fulfills EU RoHS substance requirements	Yes, No exemptions
---	--------------------

China RoHS

Environment friendly use period (EFUP)	EFUP-E
	No hazardous substances above the limits

EU REACH SVHC

REACH candidate substance (CAS No.)	No substance above 0.1 wt%
-------------------------------------	----------------------------

Phoenix Contact 2026 © - all rights reserved
<https://www.phoenixcontact.com>

Phoenix Contact USA
586 Fulling Mill Road
Middletown, PA 17057, United States
(+717) 944-1300
info@phoenixcon.com