

WR/M40-25M - Protective hose



1644889

<https://www.phoenixcontact.com/us/products/1644889>

Please be informed that the data shown in this PDF document is generated from our online catalog. Please find the complete data in the user documentation. Our general terms of use for downloads are valid.

Protective hose, for protective house screw connection, packing volume: 25 m, M40



Commercial data

Item number	1644889
Packing unit	1 m
Note	Made to order (non-returnable)
Sales key	BF66
Product key	AF7AZW
GTIN	4017918911195
Weight per piece (including packing)	4.65 kg
Weight per piece (excluding packing)	4.65 kg
Customs tariff number	39173200
Country of origin	DE

WR/M40-25M - Protective hose



1644889

<https://www.phoenixcontact.com/us/products/1644889>

Technical data

Product properties

Product type	Protective hose
--------------	-----------------

Material specifications

Color	black
Material	PA
Flammability rating according to UL 94	HB

Cable/line

External cable diameter	0.1 mm ... 42.5 mm
Bending radius, static	90.00 mm
Smallest bending radius, movable installation	90 mm

Environmental and real-life conditions

Ambient conditions

Ambient temperature (operation)	-40 °C ... 110 °C
---------------------------------	-------------------

Drawings

Dimensional drawing

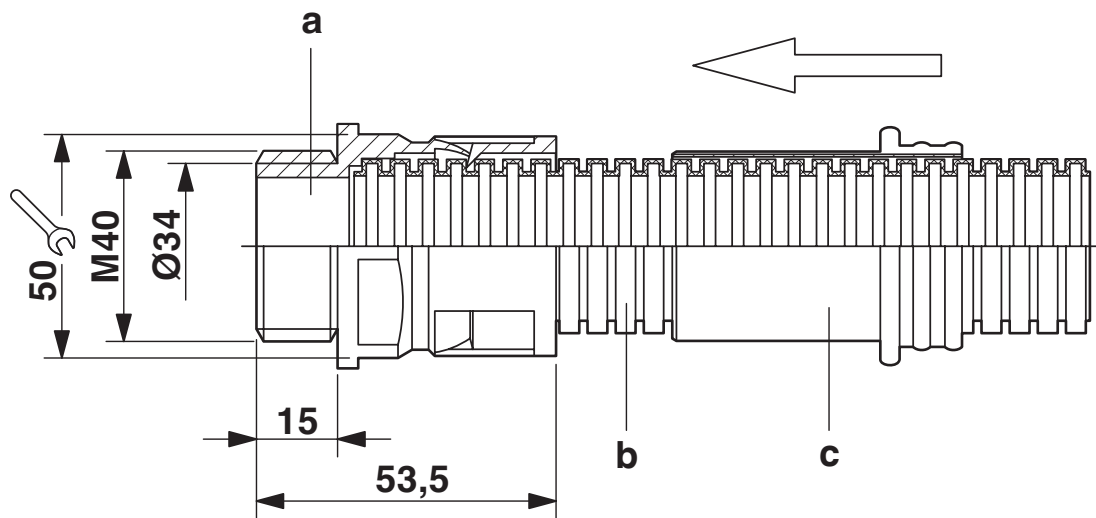

Assembly instructions for M40 corrugated pipe

a = Corrugated screw connection

b = Corrugated pipe

c = Opener

Installation note:

Cut the corrugated pipe in the groove to retain a round shape for insertion. The lighter seal (not depicted in the illustration) is positioned in the corrugated pipe screw connection below the safety latch. The darker outer seal (not depicted in the illustration) is placed over the corrugated pipe screw connection from outside. The corrugated pipe is then pushed as far as possible into the corrugated pipe screw connection and clicks into place. The screw connection is opened by placing the yellow corrugated pipe opener with force between the safety latch and the corrugated tube and the corrugated pipe is then pulled out.

WR/M40-25M - Protective hose



1644889

<https://www.phoenixcontact.com/us/products/1644889>

Environmental product compliance

EU RoHS

Fulfills EU RoHS substance requirements	Yes, No exemptions
---	--------------------

China RoHS

Environment friendly use period (EFUP)	EFUP-E
	No hazardous substances above the limits

EU REACH SVHC

REACH candidate substance (CAS No.)	No substance above 0.1 wt%
-------------------------------------	----------------------------

Phoenix Contact 2026 © - all rights reserved
<https://www.phoenixcontact.com>

Phoenix Contact USA
586 Fulling Mill Road
Middletown, PA 17057, United States
(+717) 944-1300
info@phoenixcon.com