

# HC-M-EMV-ST/3-9,5 - Connector



1636088

<https://www.phoenixcontact.com/us/products/1636088>

Please be informed that the data shown in this PDF document is generated from our online catalog. Please find the complete data in the user documentation. Our general terms of use for downloads are valid.



HEAVYCON EMC connector, pin version, 4-pos., for connecting shielded conductors with 3 ... 9. 5 mm external conductor diameter. For use in the HC-M-02-EMC-M plastic module

## Commercial data

Item number	1636088
Packing unit	1 pc
Minimum order quantity	1 pc
Sales key	BF62
Product key	AF7ACB
GTIN	4017918962920
Weight per piece (including packing)	32.808 g
Weight per piece (excluding packing)	27.2 g
Customs tariff number	85389099
Country of origin	CN

# HC-M-EMV-ST/3-9,5 - Connector

1636088

<https://www.phoenixcontact.com/us/products/1636088>

## Technical data

### Product properties

Product type	EMC insert, modular
Series	HC-M-EMV
Application	Data/signal
Number of positions	4
Connection profile	4
Contact numbering	1 - 4
No. of cable outlets	1
No. of power contacts	0
No. of control contacts	4
Contact material type	turned rolled
Shielded	yes

### Insulation characteristics

Overvoltage category	III
Degree of pollution	3

### Electrical properties

Rated voltage (III/3)	48 V
Rated surge voltage	0.8 kV
Rated current	10 A
Transmission characteristics (category)	CAT5e

### Connection data

#### Connection technology

Connection technology	Crimp connection
-----------------------	------------------

#### Conductor connection

Conductor cross-section	0.14 mm <sup>2</sup> ... 2.5 mm <sup>2</sup>
Connection cross section AWG	26 ... 14
Stripping length of the individual wire	8 mm (6 mm with 2.5 mm <sup>2</sup> )

### Dimensions

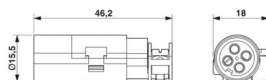
Dimensional drawing	
Width	18 mm
Height	15.5 mm
Length	46 mm

# HC-M-EMV-ST/3-9,5 - Connector



1636088

<https://www.phoenixcontact.com/us/products/1636088>

## Mechanical characteristics

Contact diameter	1.6 mm
------------------	--------

## Material specifications

Material	Zinc alloy
Flammability rating according to UL 94	V0
Contact material	Copper alloy
Contact surface material	Ag (alternatively Au)
Contact carrier material	PC

## Cable/line

External cable diameter	3 mm ... 9.5 mm
Wire diameter including insulation	2.4 mm
Stripping length of the individual wire	8 mm (6 mm with 2.5 mm <sup>2</sup> )

## Mechanical properties

### Mechanical data

Insertion/withdrawal cycles	≥ 500
-----------------------------	-------

## Environmental and real-life conditions

### Ambient conditions

Ambient temperature (operation)	-40 °C ... 85 °C
---------------------------------	------------------

## Mounting

Assembly note	Housing height ≥ 72 mm. Plug-in connections may only be operated only when there is no load/voltage.
	For use in HC-M-EMV-MOD-ST plastic module, usable CK1,6-ED-... crimp contacts

# HC-M-EMV-ST/3-9,5 - Connector

1636088

<https://www.phoenixcontact.com/us/products/1636088>

## Drawings

Dimensional drawing

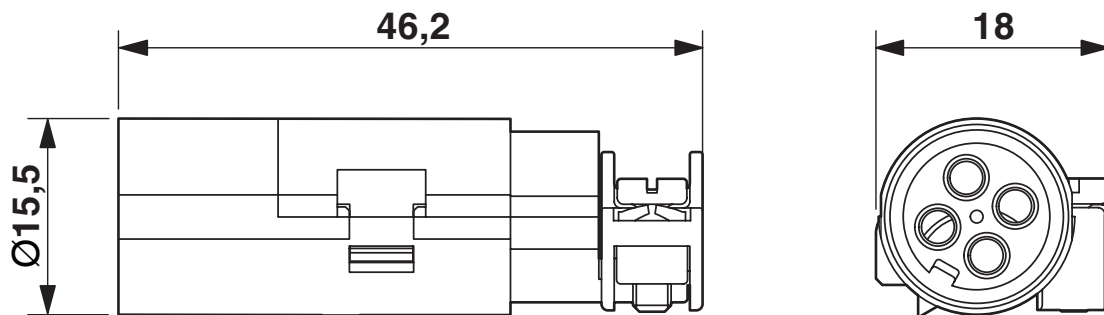

## Male insert

Dimensional drawing

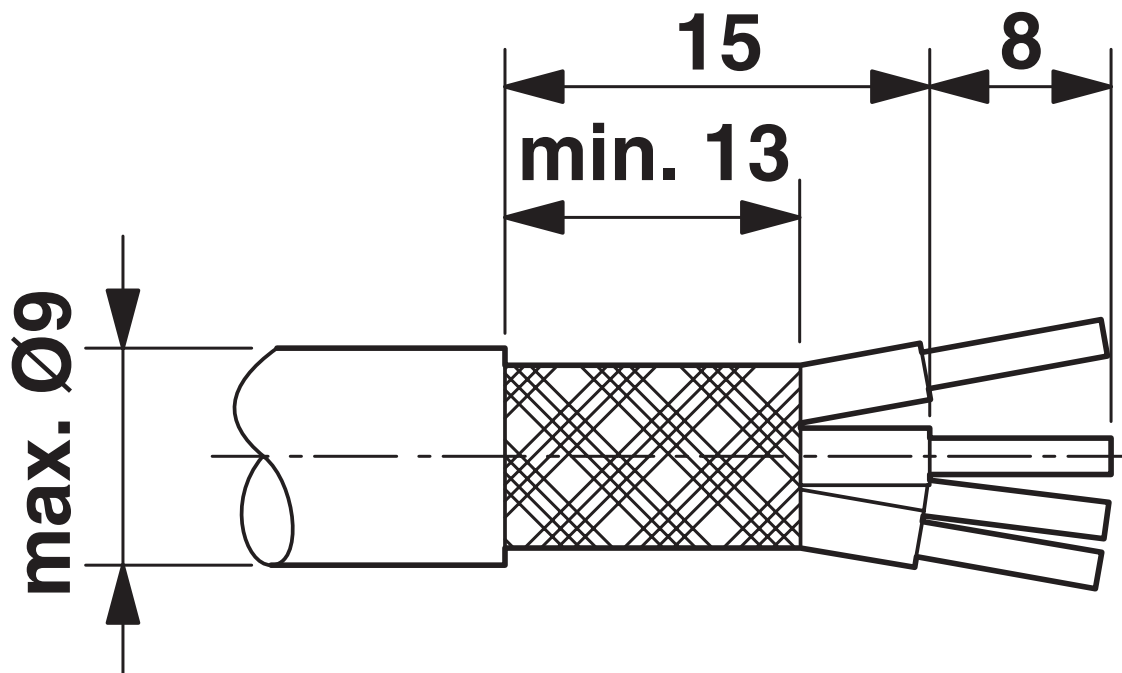

## Stripping specifications

# HC-M-EMV-ST/3-9,5 - Connector

1636088

<https://www.phoenixcontact.com/us/products/1636088>



Functional drawing

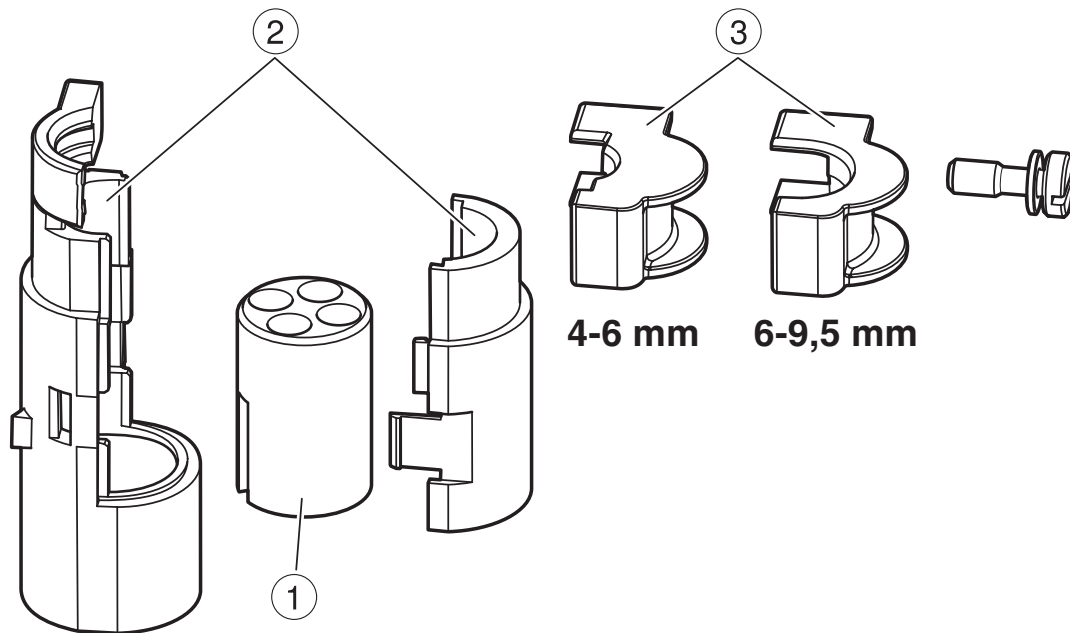

## Assembly instruction:

Strip the cable as shown. Lay the braided shield around the cable sheath, and secure with shrink sleeve. Mount the contact carrier in the EMC connector and put on the metal half-shells. Crimp the wires with crimp contacts and snap the contacts into the contact carrier (check to ensure position assignment is correct). Mount the clip and snap the EMC connector into the EMC module. Lastly, place the module in the snap-in frame.

# HC-M-EMV-ST/3-9,5 - Connector





1636088

<https://www.phoenixcontact.com/us/products/1636088>

## Approvals

To download certificates, visit the product detail page: <https://www.phoenixcontact.com/us/products/1636088>

 <b>cUL Recognized</b> Approval ID: E118976				
	Nominal voltage $U_N$	Nominal current $I_N$	Cross section AWG	Cross section $\text{mm}^2$
keine				
	42 V	9 A	- 16	-

 <b>UL Recognized</b> Approval ID: E118976				
	Nominal voltage $U_N$	Nominal current $I_N$	Cross section AWG	Cross section $\text{mm}^2$
keine				
	42 V	10 A	- 16	-

# HC-M-EMV-ST/3-9,5 - Connector



1636088

<https://www.phoenixcontact.com/us/products/1636088>

## Classifications

### ECLASS

ECLASS-13.0	27440205
ECLASS-15.0	27440205

### ETIM

ETIM 10.0	EC000438
-----------	----------

### UNSPSC

UNSPSC 21.0	39121500
-------------	----------

# HC-M-EMV-ST/3-9,5 - Connector



1636088

<https://www.phoenixcontact.com/us/products/1636088>

## Environmental product compliance

### EU RoHS

Fulfills EU RoHS substance requirements	Yes, No exemptions
---	--------------------

### China RoHS

Environment friendly use period (EFUP)	EFUP-E
	No hazardous substances above the limits

### EU REACH SVHC

REACH candidate substance (CAS No.)	No substance above 0.1 wt%
-------------------------------------	----------------------------

### EF3.1 Climate Change

CO2e kg	6.314 kg CO2e
---------	---------------

Phoenix Contact 2026 © - all rights reserved  
<https://www.phoenixcontact.com>

Phoenix Contact USA  
586 Fulling Mill Road  
Middletown, PA 17057, United States  
(+717) 944-1300  
[info@phoenixcon.com](mailto:info@phoenixcon.com)