

# EV-T2M4CC-DC125A-4,0M50ESBK00 - DC charging cable



1621650

<https://www.phoenixcontact.com/us/products/1621650>

Please be informed that the data shown in this PDF document is generated from our online catalog. Please find the complete data in the user documentation. Our general terms of use for downloads are valid.



CHARX connect, CCS type 2, DC charging cable, with vehicle charging connector and open cable end, cable: 4 m, black, straight, no liquid cooling, housing: black, gray, PHOENIX CONTACT logo, IEC 62196-3, for charging electric vehicles (EV) with direct current (DC)

## Product description

DC charging cable with vehicle charging connector and free cable end for fast charging of electric vehicles (EV) with direct current (DC) via CCS type 2 vehicle charging inlets, for installation at charging stations for e-mobility (EVSE)

## Your advantages

- Consistent design of all Phoenix Contact Vehicle Connectors and Infrastructure Plugs
- Silver-plated surface of the power and signal contacts
- Developed and produced in accordance with the IATF 16949 automotive standard and ISO 9001
- Convenient handling, thanks to the ergonomic handle and additional, rubber grip components
- Integrated temperature sensors for monitoring the temperature at the power contacts

## Commercial data

Item number	1621650
Packing unit	1 pc
Note	Made to order (non-returnable)
Sales key	EM01
Product key	XWBAAD
GTIN	4046356950527
Weight per piece (including packing)	7.355 kg
Weight per piece (excluding packing)	7.3 kg
Customs tariff number	85444290
Country of origin	DE

# EV-T2M4CC-DC125A-4,0M50ESBK00 - DC charging cable



1621650

<https://www.phoenixcontact.com/us/products/1621650>

## Technical data

### Product properties

Product type	DC charging cable
Product family	CHARX connect
Type	DC charging cable with vehicle charging connector and open cable end
Design	no liquid cooling
Charging standard	CCS type 2
Charging mode	Mode 4
Affixed logo	PHOENIX CONTACT logo

### Electrical properties

#### Charging power and current (DC charging)

Type of charging current	DC
Charging current	125 A DC
Charging power	125 kW
Rated voltage	1000 V

#### Temperature sensors (Pt 1000)

Sensor type	Pt 1000
Standards/regulations	DIN EN 60751
Attachment point	Sensor for the DC contacts
Switch-off temperature	90 °C ±1 K (equivalent to a Pt 1000 value of 1346.5 Ω)
Long-term stability	0.06 % (after 1000 hours at 130 °C)
Recommended measured current	1 mA (1 V at 0°C)
Coefficient	3850 ppm/K
Ambient temperature	-50 °C ... 130 °C (Operation)

### Material specifications

Color (Housing)	black (9005)
Color (Handle area)	gray (7042)
Color (Mating face)	black (9005)
Color (Protective cap)	black (9005)
Color (Cable)	black (9005)

### Cable/line

Cable length	4 m
Wiring standards/regulations	prEN 50620/DIN EN 50620
Wiring certifications	VDE-Reg.
Cable weight	max. 1620.00 kg/km
Cable type	Class 6
Cable type	straight

# EV-T2M4CC-DC125A-4,0M50ESBK00 - DC charging cable



1621650

<https://www.phoenixcontact.com/us/products/1621650>

Cable structure	2 x 50 mm <sup>2</sup> + 1 x 25 mm <sup>2</sup> + 3 x 2 x 0.75 mm <sup>2</sup>
External cable diameter	28.10 mm ±0.5 mm
Outer sheath, material	TPE-U
Stripping length of the sheath	140 mm ±10 mm
Stripping length	140 mm ±10 mm
Cable resistance	≤ 0.00039 Ω/m (based on a power core, at an ambient temperature of 20°C)
Bending radius	min. 281 mm (10x Ø)
Cable length	4 m
Stripping length	140 mm ±10 mm
External cable diameter	28.10 mm ±0.5 mm
Cable type	Class 6
Wiring certifications	VDE-Reg.
Wiring standards/regulations	prEN 50620/DIN EN 50620
Cable resistance	≤ 0.00039 Ω/m (based on a power core, at an ambient temperature of 20°C)

## Standards and regulations

### Standards

Standards/regulations	IEC 62196-3
-----------------------	-------------

# EV-T2M4CC-DC125A-4,0M50ESBK00 - DC charging cable



1621650

<https://www.phoenixcontact.com/us/products/1621650>

## Drawings



Make sure that the vehicle charging connector is placed in an appropriate charging connector holder, which ensures a minimum protection rating of IP24 in accordance with IEC 61851-1, for the entire time between charging. To create this charging connector holder, use the dimensions of the vehicle charging connector. Detailed dimensions can also be found in the Download area.

# EV-T2M4CC-DC125A-4,0M50ESBK00 - DC charging cable

1621650

<https://www.phoenixcontact.com/us/products/1621650>

## Schematic diagram



## Operating instructions

### Schematic diagram



The Combined Charging System (CCS) principle - standard-compliant charging system for electric vehicles, which supports both conventional AC charging and fast DC charging. Both Vehicle Connectors fit into the CCS Vehicle Inlet.

# EV-T2M4CC-DC125A-4,0M50ESBK00 - DC charging cable

1621650

<https://www.phoenixcontact.com/us/products/1621650>

Schematic diagram

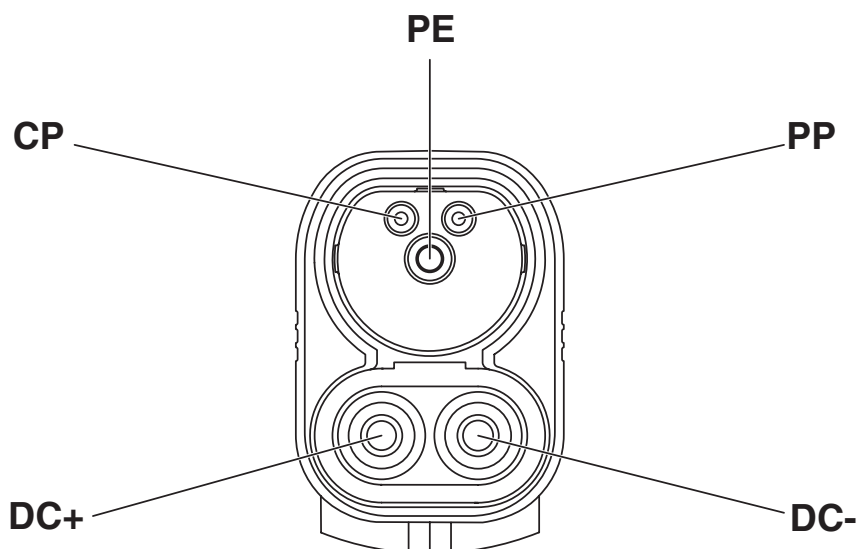

Pin assignment of the Vehicle Connector

# EV-T2M4CC-DC125A-4,0M50ESBK00 - DC charging cable

1621650

<https://www.phoenixcontact.com/us/products/1621650>

## Schematic diagram



# EV-T2M4CC-DC125A-4,0M50ESBK00 - DC charging cable

1621650

<https://www.phoenixcontact.com/us/products/1621650>

Schematic diagram



The resting position must be installed in the charging station such that the user cannot hang up the vehicle connector upside down (90° to 270°). However, positions rotated upward (45°) or downward (315°) are options for a resting position.

# EV-T2M4CC-DC125A-4,0M50ESBK00 - DC charging cable



1621650

<https://www.phoenixcontact.com/us/products/1621650>

## Classifications

### UNSPSC

UNSPSC 21.0	39121522
-------------	----------

# EV-T2M4CC-DC125A-4,0M50ESBK00 - DC charging cable



1621650

<https://www.phoenixcontact.com/us/products/1621650>

## Environmental product compliance

### China RoHS

Environment friendly use period (EFUP)	EFUP-10 An article-related China RoHS declaration table can be found in the download area for the respective article under "Manufacturer declaration". For all articles with EFUP-E, no China RoHS declaration table issued and required.
--	--

### EU REACH SVHC

REACH candidate substance (CAS No.)	No substance above 0.1 wt%
-------------------------------------	----------------------------

Phoenix Contact 2026 © - all rights reserved  
<https://www.phoenixcontact.com>

Phoenix Contact USA  
586 Fulling Mill Road  
Middletown, PA 17057, United States  
(+717) 944-1300  
[info@phoenixcon.com](mailto:info@phoenixcon.com)