

HC-D 15-TFL-53/O1M20S - Housing



1604896

<https://www.phoenixcontact.com/us/products/1604896>

Please be informed that the data shown in this PDF document is generated from our online catalog. Please find the complete data in the user documentation. Our general terms of use for downloads are valid.



HEAVYCON sleeve housing D15, for single locking latch, height 53 mm, with support 1x M20, lateral conductor exit

Commercial data

Item number	1604896
Packing unit	1 pc
Note	Made to order (non-returnable)
Sales key	BF55
Product key	AF7AAE
GTIN	4017918882303
Weight per piece (including packing)	113.07 g
Weight per piece (excluding packing)	113.07 g
Customs tariff number	85389099
Country of origin	DE

HC-D 15-TFL-53/O1M20S - Housing

1604896

<https://www.phoenixcontact.com/us/products/1604896>

Technical data

Product properties

Product type	Housing with locking latch
Housing type	Sleeve housing
Application	Standard
Type	D15
No. of cable outlets	1
Type of the screw connection	1x M20
Shielded	no
Cable outlet	lateral
Pg screw connection	none

Dimensions

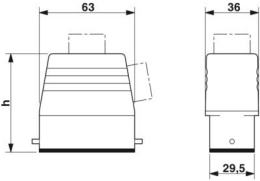
Dimensional drawing	
Width	36 mm
Height	53 mm
Length	63 mm

Material specifications

Seal material	NBR
Housing material	Die-cast aluminum
Housing surface material	Powder-coated, gray

Mechanical properties

Mechanical data

Type of the screw connection	1x M20
Locking type	Pin

Environmental and real-life conditions

Ambient conditions

Degree of protection	IP65
Ambient temperature (operation)	-40 °C ... 125 °C

HC-D 15-TFL-53/O1M20S - Housing

1604896

<https://www.phoenixcontact.com/us/products/1604896>



Drawings

Dimensional drawing

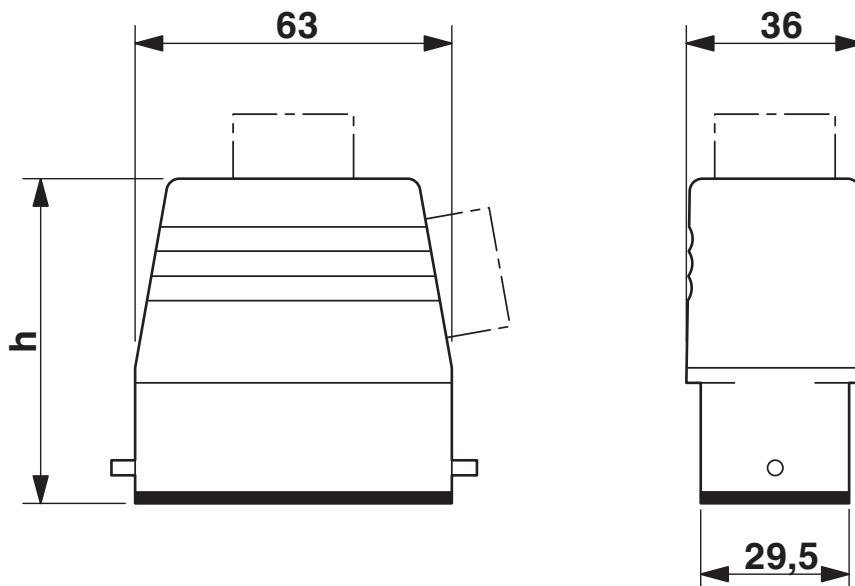

Dimensional drawing

HC-D 15-TFL-53/O1M20S - Housing

1604896

<https://www.phoenixcontact.com/us/products/1604896>



Classifications

ECLASS

ECLASS-13.0	27440202
ECLASS-15.0	27440202

HC-D 15-TFL-53/O1M20S - Housing



1604896

<https://www.phoenixcontact.com/us/products/1604896>

Environmental product compliance

EU RoHS

Fulfills EU RoHS substance requirements	Yes, No exemptions
---	--------------------

China RoHS

Environment friendly use period (EFUP)	EFUP-E
	No hazardous substances above the limits

EU REACH SVHC

REACH candidate substance (CAS No.)	No substance above 0.1 wt%
-------------------------------------	----------------------------

Phoenix Contact 2026 © - all rights reserved
<https://www.phoenixcontact.com>

Phoenix Contact USA
586 Fulling Mill Road
Middletown, PA 17057, United States
(+717) 944-1300
info@phoenixcon.com