

# SAC-5P-M12MRB/ 2,0-920 - Bus system cable



1544727

<https://www.phoenixcontact.com/us/products/1544727>

Please be informed that the data shown in this PDF document is generated from our online catalog. Please find the complete data in the user documentation. Our general terms of use for downloads are valid.



Bus system cable, CANopen®, DeviceNet™, 5-position, PUR halogen-free, red lilac RAL 4001, shielded, Plug angled M12, coding: B, on free cable end, cable length: 2 m

## Commercial data

Item number	1544727
Packing unit	1 pc
Minimum order quantity	50 pc
Product key	AF1CKD
GTIN	4046356117470
Weight per piece (including packing)	130.1 g
Weight per piece (excluding packing)	130.1 g
Country of origin	DE

# SAC-5P-M12MRB/ 2,0-920 - Bus system cable



1544727

<https://www.phoenixcontact.com/us/products/1544727>

## Technical data

### Product properties

Product type	Data cable preassembled
Number of positions	5
No. of cable outlets	1
Shielded	yes
Coding	B

### Insulation characteristics

Overvoltage category	II
Degree of pollution	3

### Interfaces

Bus system	CANopen®/DeviceNet™
Signal type/category	CANopen® DeviceNet™

### Signaling

Status display	no
Status display present	no

### Electrical properties

Insulation resistance	≥ 100 MΩ
Nominal voltage $U_N$	48 V AC 60 V DC
Nominal current $I_N$	4 A

### Mechanical properties

#### Mechanical data

Insertion/withdrawal cycles	≥ 100
-----------------------------	-------

### Material specifications

Flammability rating according to UL 94	HB
Material of grip body	TPU, hardly inflammable, self-extinguishing
Contact material	CuSn
Contact surface material	Ni/Au
Contact carrier material	TPU GF
Material for screw connection	Zinc die-cast, nickel-plated

### Connector

#### Connection 1

Type	Plug angled M12
------	-----------------

# SAC-5P-M12MRB/ 2,0-920 - Bus system cable



1544727

<https://www.phoenixcontact.com/us/products/1544727>

Number of positions	5
Coding type	B (inverse)

## Connection 2

Type	free cable end
------	----------------

## Cable/line

Cable length	2 m
--------------	-----

CANopen®/DeviceNet™, PUR, violet [920]

Dimensional drawing	
Cable weight	90 kg/km
UL AWM Style	21198 (80°C/300 V)
Number of positions	4
Shielded	yes
Cable type	CANopen®/DeviceNet™, PUR, violet [920]
Conductor structure	2xAWG24/19+2xAWG22/19
Conductor structure signal line	19x 0.13 mm
AWG signal line	24
Conductor structure, voltage supply	19x 0.15 mm
AWG power supply	22
Conductor cross-section	2x 0.25 mm <sup>2</sup> (Data cable) 2x 0.34 mm <sup>2</sup> (Power supply) 1x 0.34 mm <sup>2</sup> (Drain wire)
Wire diameter incl. insulation	1.95 mm ±0.05 mm (Data cable) 1.4 mm ±0.05 mm (Power supply)
External cable diameter	6.70 mm ±0.3 mm
Outer sheath, material	PUR
External sheath, color	red lilac RAL 4001
Conductor material	Tin-plated Cu litz wires
Material wire insulation	Foamed PE (Data cable) PE (Power supply)
Single wire, color	red-black, blue-white
Twisted pairs	2 cores to the pair
Type of pair shielding	Plastic-coated aluminum foil, aluminum side outside
Overall twist	2 pairs around a drain wire in the center to the core
Optical shield covering	80 %
Insulation resistance	≥ 5 GΩ*km (Data cable)

# SAC-5P-M12MRB/ 2,0-920 - Bus system cable



1544727

<https://www.phoenixcontact.com/us/products/1544727>

	≥ 5 GΩ*km (Power supply)
Loop resistance	≤ 181.80 Ω/km (Data cable)
	≤ 114.80 Ω/km (Power supply)
Wave impedance	120 Ω ±10 % (with 1 MHz)
Cable capacity	nom. 40 nF/km (Data cable)
Nominal voltage, cable	≤ 300 V (Peak value, not for high-power applications)
Test voltage Core/Core	2000 V (50 Hz, 1 min.)
Test voltage Core/Shield	2000.00 V (50 Hz, 1 min.)
Minimum bending radius, fixed installation	5 x D
Minimum bending radius, flexible installation	10 x D
Smallest bending radius, fixed installation	34 mm
Smallest bending radius, movable installation	67 mm
Dynamic load capacity (bending)	Max. bending cycles: 5000000, Bending radius: 70 mm, Bending radius: 10 x D, Traversing path: 4.5 m, Traversing rate: 3 m/s, Acceleration: 3 m/s <sup>2</sup> , Ambient temperature: -20 °C ... 60 °C
Shield attenuation	≤ 22.9 dB/km (with 1 MHz)
	≤ 16.4 dB/km (At 500 kHz)
	≤ 9.5 dB/km (At 125 kHz)
Halogen-free	in accordance with DIN VDE 0472 part 815
	according to IEC 60754-1
Flame resistance	IEC 60332-1-2
	in accordance with ISO 6722-1 5.22 (UN ECE-R 118.01)
Other resistance	Low adhesion
Ambient temperature (operation)	-40 °C ... 80 °C (cable, fixed installation)
	-30 °C ... 70 °C (Cable, flexible installation)
	-20 °C ... 60 °C (for installation)
	-20 °C ... 60 °C (cable, drag chain applications)

# SAC-5P-M12MRB/ 2,0-920 - Bus system cable

1544727

<https://www.phoenixcontact.com/us/products/1544727>



## Drawings

Dimensional drawing

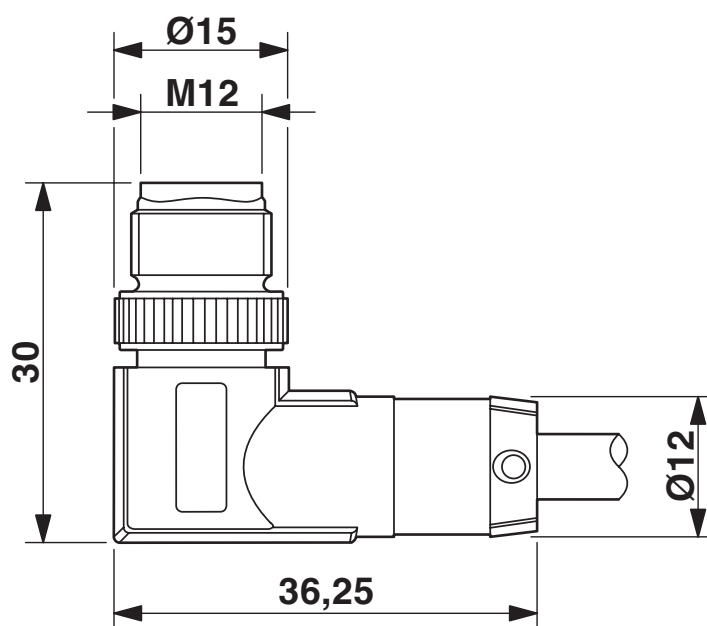

M12 x 1 male plug, angled, shielded

# SAC-5P-M12MRB/ 2,0-920 - Bus system cable

1544727

<https://www.phoenixcontact.com/us/products/1544727>



Schematic diagram



Pin assignment M12 male connector, 5-pos., B-coded, male side

# SAC-5P-M12MRB/ 2,0-920 - Bus system cable



1544727

<https://www.phoenixcontact.com/us/products/1544727>

## Classifications

### ECLASS

ECLASS-13.0	27060307
ECLASS-15.0	27060307

Phoenix Contact 2026 © - all rights reserved

<https://www.phoenixcontact.com>

Phoenix Contact USA  
586 Fulling Mill Road  
Middletown, PA 17057, United States  
(+717) 944-1300  
[info@phoenixcon.com](mailto:info@phoenixcon.com)