

SACB-8/16-L-C BK SCO - Distributor box



1543087

<https://www.phoenixcontact.com/us/products/1543087>

Please be informed that the data shown in this PDF document is generated from our online catalog. Please find the complete data in the user documentation. Our general terms of use for downloads are valid.



Distributor box, connection method: M12 socket Metal, number of slots: 8, number of positions: 5, coding: A, slot assignment: Double, status display: yes; master cable connection: Pluggable screw connection 180°, shielding: no

Commercial data

Item number	1543087
Packing unit	1 pc
Minimum order quantity	50 pc
Product key	AF3CCD
GTIN	4046356096959
Weight per piece (including packing)	372.9 g
Weight per piece (excluding packing)	344.13 g
Country of origin	PL

SACB-8/16-L-C BK SCO - Distributor box



1543087

<https://www.phoenixcontact.com/us/products/1543087>

Technical data

Product properties

Product type	Distributor box
Number of positions	5
Number of slots	8
Coding	A
LED	yes

System properties

Local diagnostics

Monitored function	Supply voltage per module
Optical representation	Green LED

Electrical properties

Max. operating voltage U_{max}	30 V DC
Local diagnostics	Supply voltage per module Green LED
	Status display I/O Yellow LED
Nominal voltage U_N	24 V DC
Rated current, total	10 A
	2x 8 A (For electrical isolation)
Max. current carrying capacity per path	2 A
Current carrying capacity per slot	4 A

Connection data

Conductor connection

Sensor/actuator connection system	M12 socket
Conductor cross-section Flexible signal line	0.14 mm ² ... 1.5 mm ²
Conductor cross-section Flexible power supply	0.14 mm ² ... 1.5 mm ²
Connection cross section AWG Flexible signal line	26 ... 16
Connection cross section AWG Flexible power supply	26 ... 16
Stripping length Signal line	7 mm
Tightening torque, cover screw	0.35 Nm
Tightening torque slot sensor/actuator cable	0.4 Nm
Tightening torque of mounting screw for fixing the housing	0.5 Nm
Tightening torque, union nut	2.5 Nm

Connection assignment

Slot/position = Wire color or connection	1 / 4 (A) = 1 / 4
	1 / 2 (B) = 1 / 2
	2 / 4 (A) = 2 / 4
	2 / 2 (B) = 2 / 2
	3 / 4 (A) = 3 / 4

SACB-8/16-L-C BK SCO - Distributor box



1543087

<https://www.phoenixcontact.com/us/products/1543087>

	3 / 2 (B) = 3 / 2
	4 / 4 (A) = 4 / 4
	4 / 2 (B) = 4 / 2
	5 / 4 (A) = 5 / 4
	5 / 2 (B) = 5 / 2
	6 / 4 (A) = 6 / 4
	6 / 2 (B) = 6 / 2
	7 / 4 (A) = 7 / 4
	7 / 2 (B) = 7 / 2
	8 / 4 (A) = 8 / 4
	8 / 2 (B) = 8 / 2
	1-8 / 1 (+ 24 V) = U _N
	1-8 / 3 (0 V) = 0 V
	1-8 / 5 (PE) = PE

Signaling

Status display present	yes
------------------------	-----

Material specifications

Material Threaded sleeve	Die-cast zinc
Material Housing	PBT
Material Molding compound	PUR
Flammability rating according to UL 94	V0
Seal material O-ring	NBR
Contact material	Cu alloy
Contact surface material	gold-plated
Contact carrier material	PA
Material of contact, master cable side	CU alloy
Material of the contact carrier on the master cable side	PA 6.6 V0
Material of contact surface, master cable side	gold-plated

Cable/line

External cable diameter	7 mm ... 12 mm
Connection method	Pluggable screw connection

Environmental and real-life conditions

Ambient conditions

Degree of protection	IP65
	IP67
	IP69K
Ambient temperature (operation)	-30 °C ... 80 °C

SACB-8/16-L-C BK SCO - Distributor box

1543087

<https://www.phoenixcontact.com/us/products/1543087>

Drawings

Dimensional drawing

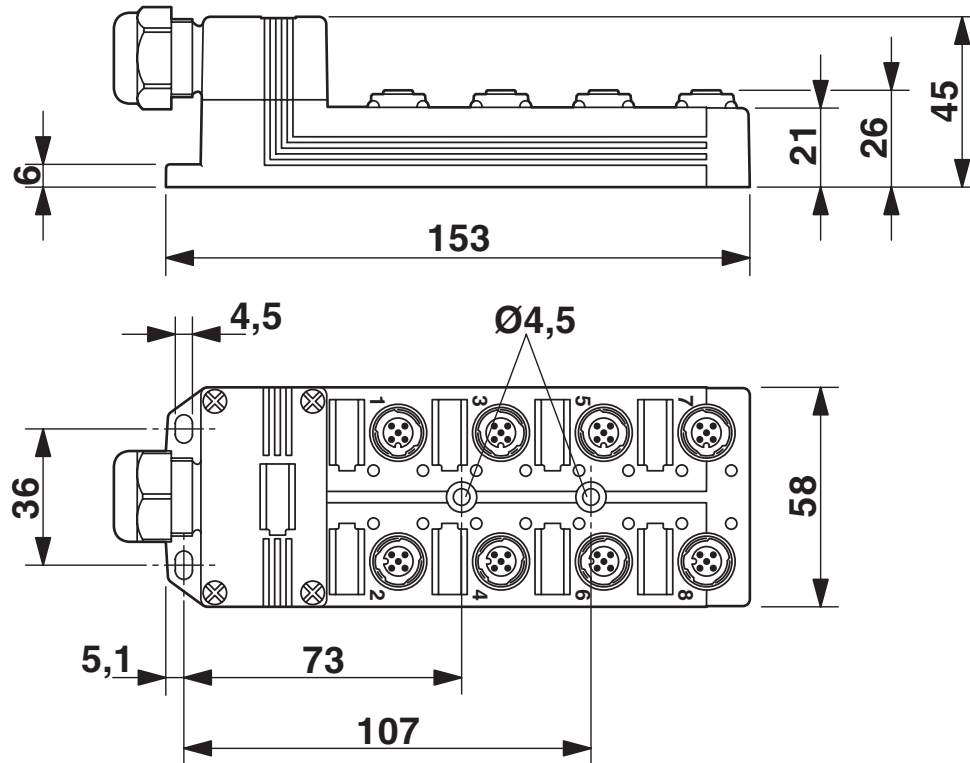

Schematic diagram

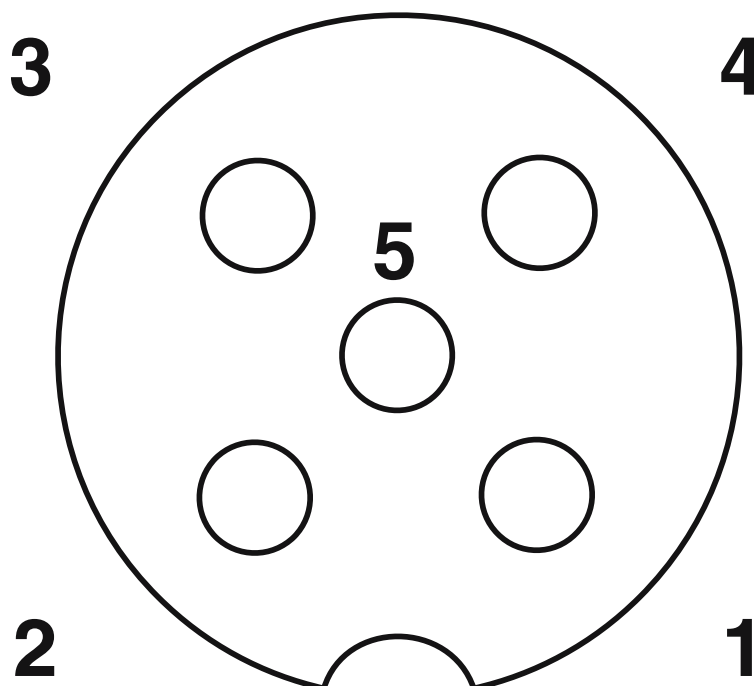

M12 slot, socket, 5-pos.

SACB-8/16-L-C BK SCO - Distributor box

1543087

<https://www.phoenixcontact.com/us/products/1543087>

Schematic diagram



Potential U_{N1} and U_{N2} bridged

SACB-8/16-L-C BK SCO - Distributor box

1543087

<https://www.phoenixcontact.com/us/products/1543087>

Schematic diagram

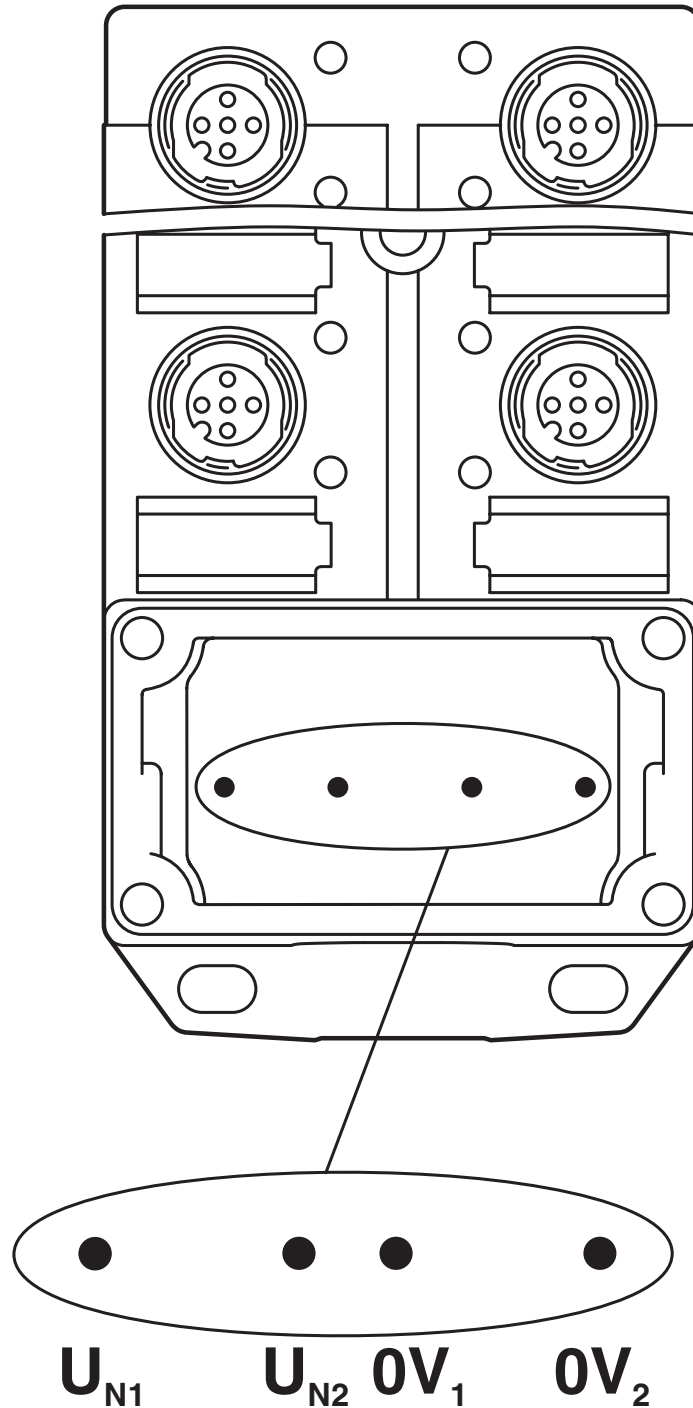

Electrically isolated

SACB-8/16-L-C BK SCO - Distributor box



1543087

<https://www.phoenixcontact.com/us/products/1543087>

Circuit diagram



SACB-8/16-L-C BK SCO - Distributor box



1543087

<https://www.phoenixcontact.com/us/products/1543087>

Classifications

ECLASS

ECLASS-13.0	27440111
ECLASS-15.0	27440111

SACB-8/16-L-C BK SCO - Distributor box



1543087

<https://www.phoenixcontact.com/us/products/1543087>

Environmental product compliance

China RoHS

Environment friendly use period (EFUP)	EFUP-50
	An article-related China RoHS declaration table can be found in the download area for the respective article under "Manufacturer declaration". For all articles with EFUP-E, no China RoHS declaration table issued and required.

EU REACH SVHC

REACH candidate substance (CAS No.)	No substance above 0.1 wt%
-------------------------------------	----------------------------

Phoenix Contact 2026 © - all rights reserved
<https://www.phoenixcontact.com>

Phoenix Contact USA
586 Fulling Mill Road
Middletown, PA 17057, United States
(+717) 944-1300
info@phoenixcon.com