

SAC-2P- 5,0-910/M12FRB - Bus system cable



1517754

<https://www.phoenixcontact.com/us/products/1517754>

Please be informed that the data shown in this PDF document is generated from our online catalog. Please find the complete data in the user documentation. Our general terms of use for downloads are valid.



Bus system cable, PROFIBUS, 2-position, PUR halogen-free, red lilac RAL 4001, shielded, free cable end, on Socket angled M12, coding: B, cable length: 5 m

Commercial data

Item number	1517754
Packing unit	1 pc
Minimum order quantity	50 pc
Product key	AF1CKC
GTIN	4017918936754
Weight per piece (including packing)	371 g
Weight per piece (excluding packing)	371 g
Country of origin	PL

SAC-2P- 5,0-910/M12FRB - Bus system cable



1517754

<https://www.phoenixcontact.com/us/products/1517754>

Technical data

Product properties

Product type	Data cable preassembled
Number of positions	2
No. of cable outlets	1
Shielded	yes
Coding	B

Insulation characteristics

Overvoltage category	II
Degree of pollution	3

Interfaces

Bus system	PROFIBUS
Signal type/category	PROFIBUS

Signaling

Status display	no
Status display present	no

Electrical properties

Insulation resistance	$\geq 100 \text{ M}\Omega$
Nominal voltage U_N	48 V AC
	60 V DC
Nominal current I_N	4 A

Mechanical properties

Mechanical data

Insertion/withdrawal cycles	≥ 100
-----------------------------	------------

Material specifications

Flammability rating according to UL 94	V0
Seal material	NBR
Material of grip body	TPU, hardly inflammable, self-extinguishing
Contact material	CuSn
Contact surface material	Ni/Au
Contact carrier material	PA 6.6
Material for screw connection	Zinc die-cast, nickel-plated

Connector

Connection 1

Type	free cable end
------	----------------

SAC-2P- 5,0-910/M12FRB - Bus system cable

1517754

<https://www.phoenixcontact.com/us/products/1517754>

Connection 2

Type	Socket angled M12
Number of positions	2
Coding type	B (inverse)

Cable/line

Cable length	5 m
--------------	-----

PROFIBUS [910]

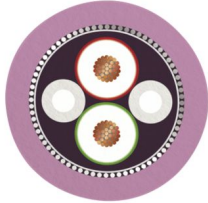
Dimensional drawing	
UL AWM Style	21198 (80°C/300 V)
Number of positions	2
Shielded	yes
Cable type	PROFIBUS [910]
Conductor structure	1x2xAWG24/19
AWG signal line	24
Conductor cross-section	2x 0.25 mm ² (Signal line)
Wire diameter incl. insulation	2.55 mm ±0.05 mm
External cable diameter	7.70 mm ±0.02 mm
Outer sheath, material	PUR
External sheath, color	red lilac RAL 4001
Conductor material	Tin-plated Cu litz wires
Single wire, color	red, green
Overall twist	2 cores with 2 fillers to the core
Optical shield covering	80 %
Insulation resistance	≥ 5 GΩ*km
Wave impedance	150 Ω ±10 % (3 MHz ... 20 MHz)
Nominal voltage, cable	≤ 125 V
Test voltage Core/Core	2000 V (50 Hz, 1 min.)
Test voltage Core/Shield	2000.00 V (50 Hz, 1 min.)
Minimum bending radius, fixed installation	4 x D
Minimum bending radius, flexible installation	8 x D
Dynamic load capacity (bending)	Max. bending cycles: 4000000, Bending radius: 65 mm, Bending radius: 15 x D, Traversing path: 4.5 m, Traversing rate: 3 m/s, Acceleration: 3 m/s ²
Shield attenuation	≤ 4.9 dB (at 16 MHz) ≤ 4.9 dB (at 4 MHz)

SAC-2P- 5,0-910/M12FRB - Bus system cable



1517754

<https://www.phoenixcontact.com/us/products/1517754>

	≤ 0.5 dB (at 38.4 kHz)
	≤ 0.3 dB (at 9.6 kHz)
Halogen-free	in accordance with DIN VDE 0472 part 815 according to IEC 60754-1
Flame resistance	UL 1581, Section 1060 and UL 2556, Section 9.3 (FT1) UL 1581, Section 1100 and UL 2556, Section 9.1 (HFT/FT2) IEC 60332-1-2
Resistance to oil	in accordance with DIN EN 60811-404
Ambient temperature (operation)	-40 °C ... 80 °C (cable, fixed installation) -30 °C ... 70 °C (Cable, flexible installation) -20 °C ... 60 °C (for installation) -20 °C ... 60 °C (cable, drag chain applications)

SAC-2P- 5,0-910/M12FRB - Bus system cable

1517754

<https://www.phoenixcontact.com/us/products/1517754>

Drawings

Dimensional drawing



M12 x 1 socket, angled, shielded

Schematic diagram

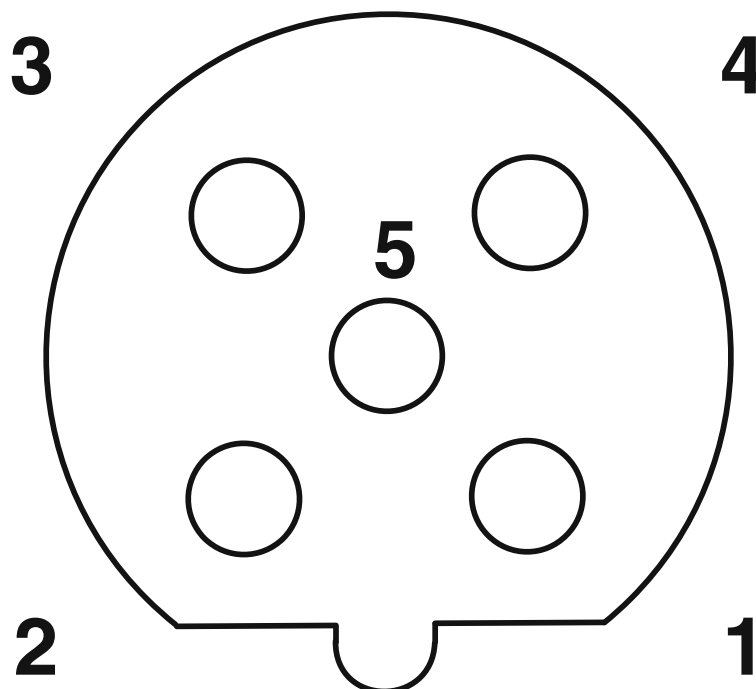

Pin assignment M12 socket, 5-pos., B-coded, female side

SAC-2P- 5,0-910/M12FRB - Bus system cable



1517754

<https://www.phoenixcontact.com/us/products/1517754>

Circuit diagram



Contact assignment of the M12 socket

SAC-2P- 5,0-910/M12FRB - Bus system cable



1517754

<https://www.phoenixcontact.com/us/products/1517754>

Classifications

ECLASS

ECLASS-13.0	27060307
ECLASS-15.0	27060307

Phoenix Contact 2026 © - all rights reserved

<https://www.phoenixcontact.com>

Phoenix Contact USA
586 Fulling Mill Road
Middletown, PA 17057, United States
(+717) 944-1300
info@phoenixcon.com