

QPD W 4PE2,5 9-16 M25 DT BK - Panel feed-through



1411433

<https://www.phoenixcontact.com/us/products/1411433>

Please be informed that the data shown in this PDF document is generated from our online catalog. Please find the complete data in the user documentation. Our general terms of use for downloads are valid.



QUICKON panel feed-through, black, 4+PE-pos., 1.0 mm² ... 2.5 mm²/690 V/20 A, with QUICKON nut, for cable diameter of 9 mm ... 16 mm, with push-in spring-cage connection.

Your advantages

- Innovative and time saving - QUICKON fast connection for time saving of up to 80 % for on-site connection
- Robust throughout: housing with IP68/IP69K and IK07 protection for a wide range of applications
- Safer connection with mechanical coding to protect against mismatching, and touch-proof protection in accordance with DIN EN 0105
- Efficient - by using panel feed-throughs, devices no longer need to be opened in order to connect cables

Commercial data

Item number	1411433
Packing unit	1 pc
Minimum order quantity	1 pc
Sales key	BF50
Product key	AF6ACB
GTIN	4046356932325
Weight per piece (including packing)	62 g
Weight per piece (excluding packing)	62 g
Customs tariff number	85366990
Country of origin	PL

1411433

<https://www.phoenixcontact.com/us/products/1411433>

Technical data

Product properties

Product type	Panel feed-through
Product family	QPD
Type	QPD 5x2,5
Number of positions	5
Connection profile	4+PE
Position marking	1, 2, 3, N, PE
Number of connections	10
Number of connections per position	1
Coding	coded

Insulation characteristics

Overvoltage category	III
Degree of pollution	3

Connection data

Connection technology

Connection method On the device side	Push-in connection
Connection method On the field side	IDC connection
Frequency of connections between conductors of the same cross section	max. 10
	10

Conductor connection

Conductor cross-section flexibel	1 mm ² ... 2.5 mm ²
Conductor cross-section solid	1 mm ² ... 2.5 mm ²
Connection cross section AWG	16 ... 14
Tightening torque Union nut	10 Nm
Tightening torque Locking nut	5 Nm
Wrench size Union nut	27 mm
Wrench size Locking nut	30 mm

Dimensions

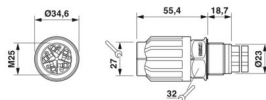
Dimensional drawing	
Width	34.6 mm
Height	34.6 mm
Length	74.1 mm
Diameter	34.6 mm
Wrench size	27 mm

QPD W 4PE2,5 9-16 M25 DT BK - Panel feed-through



1411433

<https://www.phoenixcontact.com/us/products/1411433>

Wrench size for mounting	27 mm
--------------------------	-------

Electrical properties

Rated surge voltage (II/2)	8 kV
Rated surge voltage (III/2)	8 kV
Rated surge voltage (III/3)	6 kV
Rated current	20 A
Contact resistance	< 3 mΩ
rated voltage (II/2)	1000 V
rated voltage (III/2)	1000 V
Rated voltage (III/3)	690 V
Nominal voltage U_N	690 V AC 690 V DC
Nominal current I_N	20 A

Mechanical properties

Mechanical data

Insertion/withdrawal cycles	max. 50 (QUICKON connections max. 10)
-----------------------------	---------------------------------------

Material specifications

Color	black (RAL 9005)
Material Housing	PA
Material Contact	Cu
Material Contact surface	silver-plated
Material Seal	NBR
Flammability rating according to UL 94	V0
Material wire insulation	PVC/PE/TPE/rubber

Cable/line

Structure of individual litz in acc. with VDE 0295 / smallest wire diameter	VDE 0295 class 1 to 6/min. 0.15 mm
External cable diameter	9 mm ... 16 mm
Wire diameter including insulation	2 mm ... 3.8 mm
Stripping length of the individual wire	12 mm
Position marking	1, 2, 3, N, PE
Material wire insulation	PVC/PE/TPE/rubber

Mounting

Mounting type	Front mounting M25
Assembly note	For 2.5 mm ² cables with ferrule, only CRIMPFOX 10S pliers (1212045) with square crimp can be used. CRIMPFOX 6H hexagonal crimping pliers (1212046) cannot be used, because the diameter on the diagonal is too large.

Environmental and real-life conditions

QPD W 4PE2,5 9-16 M25 DT BK - Panel feed-through



1411433

<https://www.phoenixcontact.com/us/products/1411433>

Ambient conditions

Degree of protection	IP66
	IP68 (2 m / 24 h)
	IP69K
	Touch-proof when not plugged in (IP2X)
Impact strength	IK07
Ambient temperature (operation)	-40 °C ... 100 °C
Temperature when conductor connected	-5 °C ... 50 °C
Ambient temperature (storage/transport)	-40 °C ... 80 °C

QPD W 4PE2,5 9-16 M25 DT BK - Panel feed-through



1411433

<https://www.phoenixcontact.com/us/products/1411433>

Drawings

Dimensional drawing

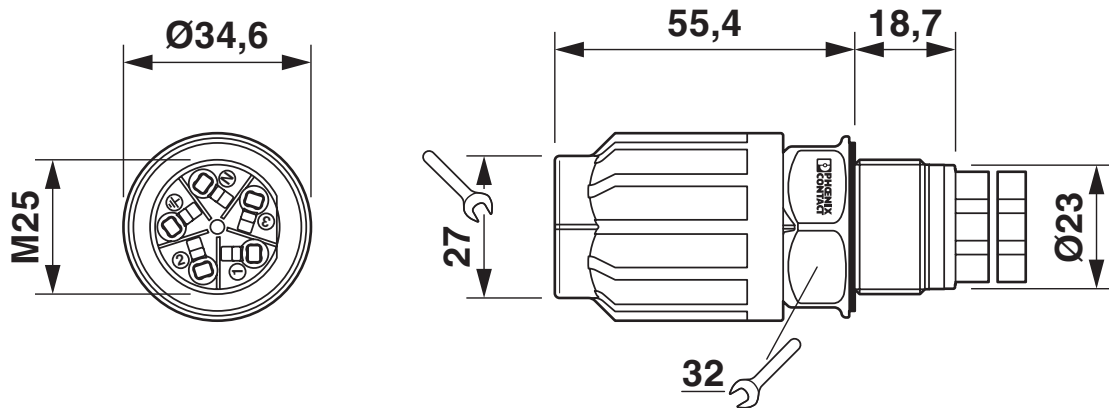

Dimensional drawing: QPD W...

Dimensional drawing

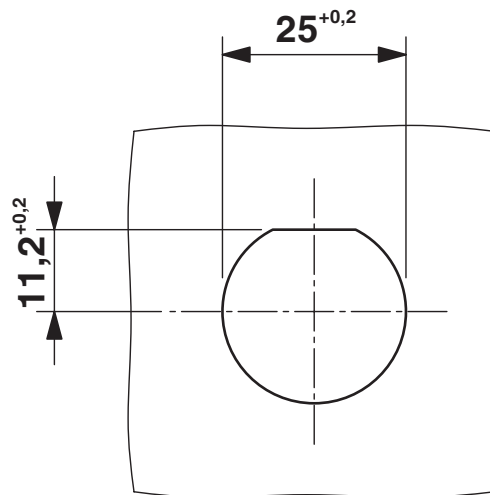

Panel cutout

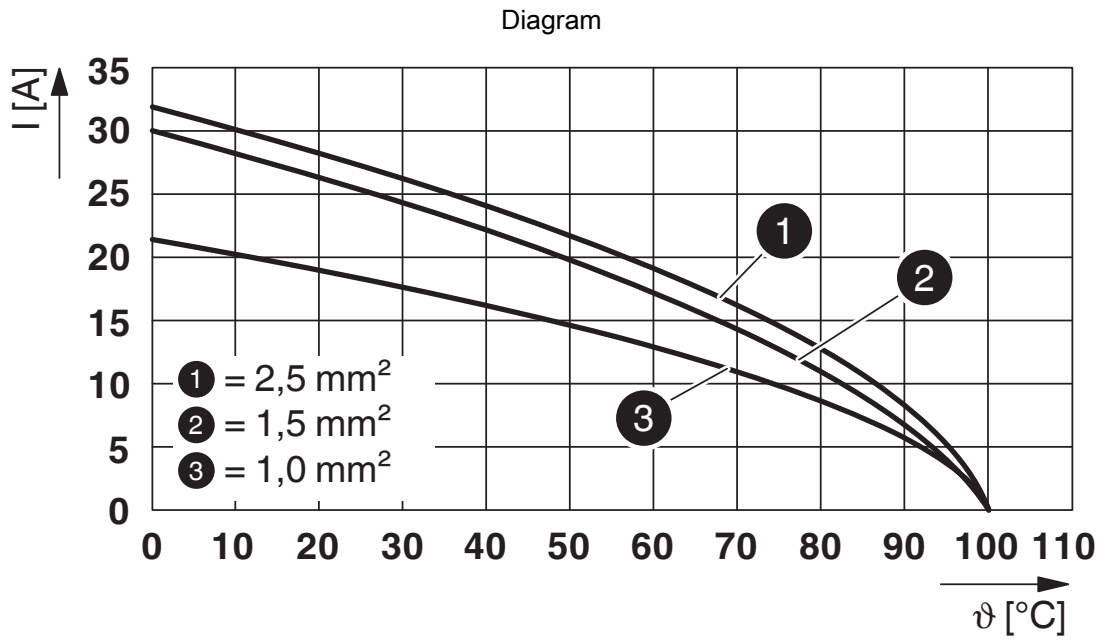

Derating diagram

1411433

<https://www.phoenixcontact.com/us/products/1411433>

Approvals

To download certificates, visit the product detail page: <https://www.phoenixcontact.com/us/products/1411433>



DNV GL

Approval ID: TAE00003J5



UL Listed

Approval ID: E468743

	Nominal voltage U_N	Nominal current I_N	Cross section AWG	Cross section mm^2
keine				
	600 V	10 A	- 14	-



cUL Listed

Approval ID: E468743

	Nominal voltage U_N	Nominal current I_N	Cross section AWG	Cross section mm^2
keine				
	600 V	10 A	- 14	-

1411433

<https://www.phoenixcontact.com/us/products/1411433>

Classifications

ECLASS

ECLASS-13.0	27440602
ECLASS-15.0	27440602

ETIM

ETIM 10.0	EC002566
-----------	----------

UNSPSC

UNSPSC 21.0	39121500
-------------	----------

1411433

<https://www.phoenixcontact.com/us/products/1411433>

Environmental product compliance

EU RoHS

Fulfills EU RoHS substance requirements	Yes, No exemptions
---	--------------------

China RoHS

Environment friendly use period (EFUP)	EFUP-E
	No hazardous substances above the limits

EU REACH SVHC

REACH candidate substance (CAS No.)	No substance above 0.1 wt%
-------------------------------------	----------------------------

EF3.1 Climate Change

CO2e kg	1.003 kg CO2e
---------	---------------

Phoenix Contact 2026 © - all rights reserved
<https://www.phoenixcontact.com>

Phoenix Contact USA
586 Fulling Mill Road
Middletown, PA 17057, United States
(+717) 944-1300
info@phoenixcon.com