

# CUC-V14-F2ZNI-EM/24FN5:FC - Panel-mount frame



1408235

<https://www.phoenixcontact.com/us/products/1408235>

Please be informed that the data shown in this PDF document is generated from our online catalog. Please find the complete data in the user documentation. Our general terms of use for downloads are valid.



Push/pull panel mounting frame, metal, version 14, including contact insert with spring-cage connection, flexible coding, for rectangular mounting cutout, with seal, without fixing screws

## Commercial data

Item number	1408235
Packing unit	1 pc
Minimum order quantity	1 pc
Sales key	AB17
Product key	ABNOJA
GTIN	4046356801898
Weight per piece (including packing)	63.5 g
Weight per piece (excluding packing)	63.5 g
Customs tariff number	85366990
Country of origin	DE

# CUC-V14-F2ZNI-EM/24FN5:FC - Panel-mount frame



1408235

<https://www.phoenixcontact.com/us/products/1408235>

## Technical data

### Product properties

Product type	Panel-mount frame
Type	MSTB
Number of positions	5
Shielded	no

### Insulation characteristics

Degree of pollution	2
---------------------	---

### Electrical properties

Rated voltage (II/2)	630 V
Rated voltage (III/2)	400 V
Rated voltage (III/3)	24 V
	250 V
Rated surge voltage (II/2)	4 kV
Rated surge voltage (III/2)	4 kV
Rated surge voltage (III/3)	4 kV
Rated current	16 A (at 20 °C)
	16 A

### Connection data

#### Connection technology

Connection method	Spring-cage connection
-------------------	------------------------

### Dimensions

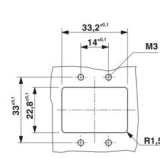
Dimensional drawing	
Width	36.2 mm
Height	42 mm
Length	41.9 mm

### Material specifications

Color	silver
Flammability rating according to UL 94	V0
Seal material	NBR

### Mechanical properties

#### Mechanical data

# CUC-V14-F2ZNI-EM/24FN5:FC - Panel-mount frame



1408235

<https://www.phoenixcontact.com/us/products/1408235>

Insertion/withdrawal cycles	≥ 100
-----------------------------	-------

## Environmental and real-life conditions

### Ambient conditions

Degree of protection	IP65/IP67
Ambient temperature (operation)	-40 °C ... 70 °C
Ambient temperature (storage/transport)	-40 °C ... 85 °C

# CUC-V14-F2ZNI-EM/24FN5:FC - Panel-mount frame



1408235

<https://www.phoenixcontact.com/us/products/1408235>

## Drawings

Dimensional drawing

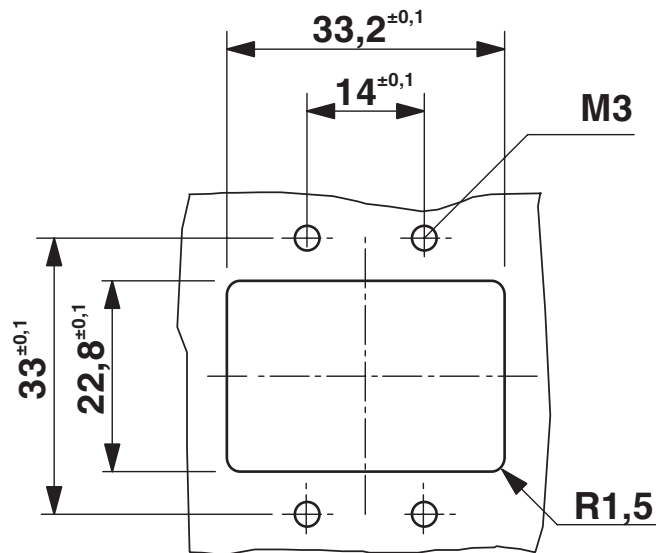

Mounting cutout

# CUC-V14-F2ZNI-EM/24FN5:FC - Panel-mount frame



1408235

<https://www.phoenixcontact.com/us/products/1408235>

## Approvals

To download certificates, visit the product detail page: <https://www.phoenixcontact.com/us/products/1408235>

 <b>UL Recognized</b> Approval ID: E118976				
	Nominal voltage $U_N$	Nominal current $I_N$	Cross section AWG	Cross section $\text{mm}^2$
keine				
	24 V	16 A	- 14	-

1408235

<https://www.phoenixcontact.com/us/products/1408235>

## Classifications

### ECLASS

ECLASS-13.0	27440312
ECLASS-15.0	27440210

### ETIM

ETIM 10.0	EC002310
-----------	----------

### UNSPSC

UNSPSC 21.0	39121400
-------------	----------

1408235

<https://www.phoenixcontact.com/us/products/1408235>

## Environmental product compliance

### EU RoHS

Fulfills EU RoHS substance requirements	Yes, No exemptions
-----------------------------------------	--------------------

### China RoHS

Environment friendly use period (EFUP)	EFUP-E
	No hazardous substances above the limits

### EU REACH SVHC

REACH candidate substance (CAS No.)	6,6'-di-tert-butyl-2,2'-methylenedi-p-cresol(CAS: 119-47-1)
SCIP	64b172a3-ad1a-4e6e-801c-d7ed6dfabadd

### EF3.1 Climate Change

CO2e kg	0.7 kg CO2e
---------	-------------

Phoenix Contact 2026 © - all rights reserved

<https://www.phoenixcontact.com>

Phoenix Contact USA  
586 Fulling Mill Road  
Middletown, PA 17057, United States  
(+717) 944-1300  
[info@phoenixcon.com](mailto:info@phoenixcon.com)