

# EO-CF/PT/LED/YE - Socket



1068075

<https://www.phoenixcontact.com/us/products/1068075>

Please be informed that the data shown in this PDF document is generated from our online catalog. Please find the complete data in the user documentation. Our general terms of use for downloads are valid.



Socket, with light indicator, Pin connector pattern type CF, connection method: Push-in spring connection, color: yellow, nom. voltage: 250 V AC (50 Hz), nominal current: 16 A, for mounting on a DIN rail in the service interface or direct mounting, standards/specifications: VDE 0620-1, IEC 60884-1, Country marking: Germany

## Commercial data

Item number	1068075
Packing unit	5 pc
Minimum order quantity	5 pc
Sales key	BE76
Product key	BE7621
GTIN	4055626739731
Weight per piece (including packing)	72.79 g
Weight per piece (excluding packing)	72.7 g
Customs tariff number	85366990
Country of origin	PL

## Technical data

### Notes

Notes on operation	This socket is not designed for applications with high loads (HL), such as chargers for electric vehicles and large radiant heaters.
--------------------	--

### General

Note	The nominal current does not apply for fuse versions. In this case, the current is determined by the fuse.
------	--

### Product properties

Product type	Socket
Country ID	Germany

### Electrical properties

Maximum power dissipation for nominal condition	1.8 W
---	-------

### Connection data

Connection method	Push-in spring connection
Note	The electrical outlets with Push-in connection are not designed for through-wiring. Connect a maximum of one conductor to each terminal point. Multiple assignment of one terminal point is not permitted.
Stripping length	10 mm
Internal cylindrical gage	A3 B3
Conductor cross-section rigid	0.2 mm <sup>2</sup> ... 4 mm <sup>2</sup>
Cross section AWG	24 ... 12 (converted acc. to IEC)
Conductor cross-section flexible	0.25 mm <sup>2</sup> ... 2.5 mm <sup>2</sup>
Conductor cross-section, flexible [AWG]	24 ... 14 (converted acc. to IEC)
Conductor cross-section flexible (ferrule without plastic sleeve)	0.25 mm <sup>2</sup> ... 2.5 mm <sup>2</sup>
Flexible conductor cross-section (ferrule with plastic sleeve)	0.25 mm <sup>2</sup> ... 2.5 mm <sup>2</sup>
Conductor cross-section flexible (2 conductors with the same cross-section, with TWIN ferrule and plastic sleeve)	0.25 mm <sup>2</sup> ... 2.5 mm <sup>2</sup>
Nominal current	16 A
Nominal voltage	250 V AC (50 Hz)

### Connection cross sections directly pluggable

Conductor cross-section rigid	0.5 mm <sup>2</sup> ... 4 mm <sup>2</sup>
Conductor cross-section flexible (ferrule without plastic sleeve)	1 mm <sup>2</sup> ... 2.5 mm <sup>2</sup>
Flexible conductor cross-section (ferrule with plastic sleeve)	1 mm <sup>2</sup> ... 2.5 mm <sup>2</sup>

### Signaling

Status display	yes
----------------	-----

### Dimensions

# EO-CF/PT/LED/YE - Socket

1068075

<https://www.phoenixcontact.com/us/products/1068075>

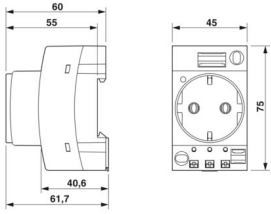
Dimensional drawing	
Width	45 mm
Height	75 mm
Depth	62.1 mm
Depth on NS 35/7,5	63 mm
Depth on NS 35/15	70.5 mm
Hole diameter	4.4 mm

## Material specifications

Color	yellow (RAL 1018)
Flammability rating according to UL 94	V0
Insulating material	PA
Contact material	CuZn38
Static insulating material application in cold	-60 °C
Temperature index of insulation material (DIN EN 60216-1 (VDE 0304-21))	130 °C
Relative insulation material temperature index (Elec., UL 746 B)	130 °C
Fire protection for rail vehicles (DIN EN 45545-2) R22	HL 1 - HL 3
Fire protection for rail vehicles (DIN EN 45545-2) R23	HL 1 - HL 3
Fire protection for rail vehicles (DIN EN 45545-2) R24	HL 1 - HL 3
Fire protection for rail vehicles (DIN EN 45545-2) R26	HL 1 - HL 3
Calorimetric heat release NFPA 130 (ASTM E 1354)	28 MJ/kg
Surface flammability NFPA 130 (ASTM E 162)	passed
Specific optical density of smoke NFPA 130 (ASTM E 662)	passed
Smoke gas toxicity NFPA 130 (SMP 800C)	passed

## Connector

Type of plug	Pin connector pattern type CF
--------------	-------------------------------

## Environmental and real-life conditions

### Oscillation/broadband noise

Specification	DIN EN 50155 (VDE 0115-200):2022-06
Spectrum	Long life test category 2, bogie-mounted
Frequency	$f_1 = 5 \text{ Hz}$ to $f_2 = 250 \text{ Hz}$
ASD level	6.12 (m/s <sup>2</sup> ) <sup>2</sup> /Hz
Acceleration	3.12g
Test duration per axis	5 h
Test directions	X-, Y- and Z-axis

1068075

<https://www.phoenixcontact.com/us/products/1068075>

Result	Test passed
--------	-------------

## Shocks

Specification	DIN EN 50155 (VDE 0115-200):2022-06
Pulse shape	Half-sine
Acceleration	30g
Shock duration	18 ms
Number of shocks per direction	3
Test directions	X-, Y- and Z-axis (pos. and neg.)
Result	Test passed

## Ambient conditions

Degree of protection	IP20
Ambient temperature (operation)	-45 °C ... 70 °C (max. operating temperature range including self-heating, see derating curve)
Ambient temperature (storage/transport)	-45 °C ... 70 °C
Permissible humidity (storage/transport)	30 % ... 70 %
Resistance against air humidity	95 % ... 48 h

## Standards and regulations

## Standards

Standards/regulations	VDE 0620-1
	IEC 60884-1

## Mounting

Mounting type	for mounting on a DIN rail in the service interface or direct mounting
---------------	--

## Drawings

Dimensional drawing

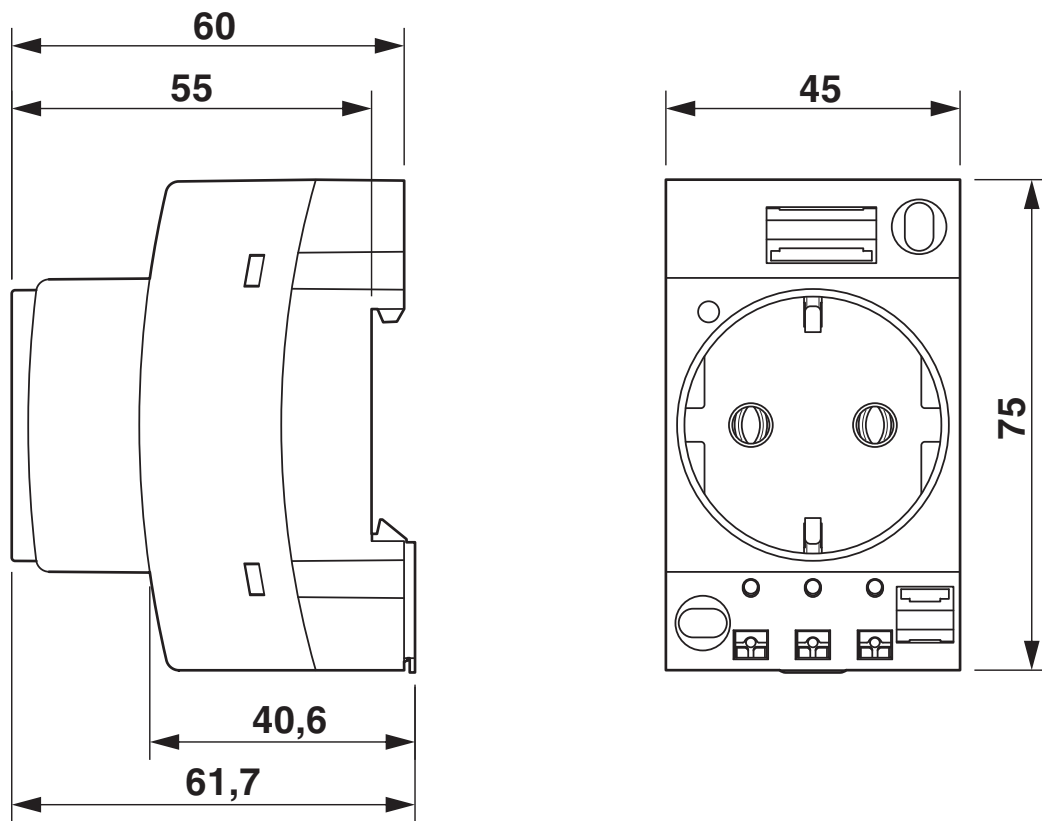

Diagram

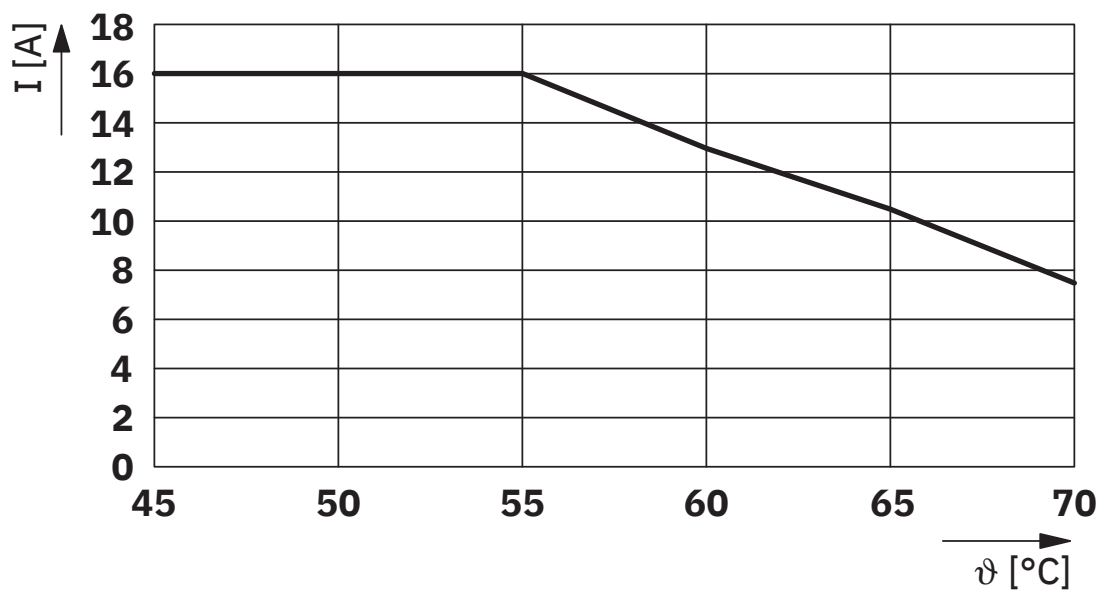

# EO-CF/PT/LED/YE - Socket

1068075

<https://www.phoenixcontact.com/us/products/1068075>



Circuit diagram

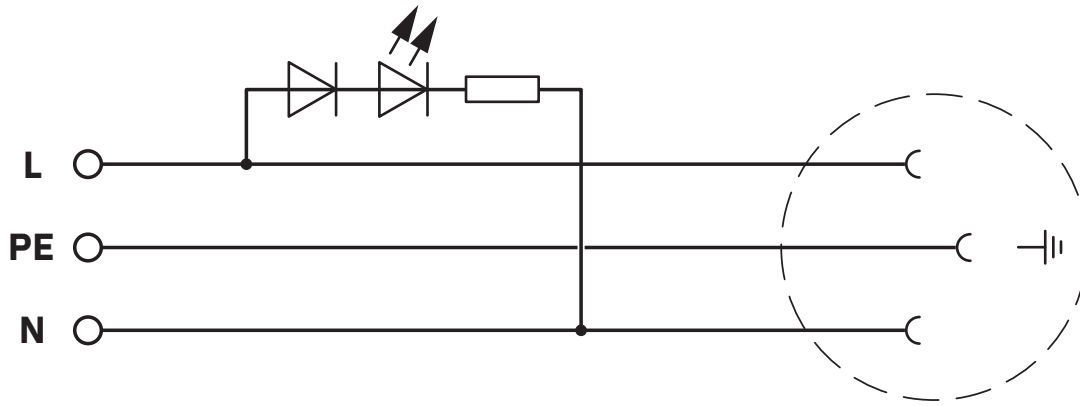

# EO-CF/PT/LED/YE - Socket





1068075

<https://www.phoenixcontact.com/us/products/1068075>

## Approvals

To download certificates, visit the product detail page: <https://www.phoenixcontact.com/us/products/1068075>

 <b>VDE Gutachten mit Fertigungsüberwachung</b> Approval ID: 40047713				
	Nominal voltage $U_N$	Nominal current $I_N$	Cross section AWG	Cross section $\text{mm}^2$
keine				
	250 V	16 A	-	-

 <b>EAC-RoHS</b> Approval ID: RU D-DE.HB49.B.00025	
--	--

 <b>EAC</b> Approval ID: KZ7500651131219505	
---	--

# EO-CF/PT/LED/YE - Socket



1068075

<https://www.phoenixcontact.com/us/products/1068075>

## Classifications

### ECLASS

ECLASS-13.0	27142305
ECLASS-15.0	27142305

### ETIM

ETIM 10.0	EC001663
-----------	----------

### UNSPSC

UNSPSC 21.0	39121400
-------------	----------

1068075

<https://www.phoenixcontact.com/us/products/1068075>

## Environmental product compliance

### EU RoHS

Fulfills EU RoHS substance requirements	Yes
Exemption	7(a), 7(c)-I

### China RoHS

Environment friendly use period (EFUP)	EFUP-50
	An article-related China RoHS declaration table can be found in the download area for the respective article under "Manufacturer declaration". For all articles with EFUP-E, no China RoHS declaration table issued and required.

### EU REACH SVHC

REACH candidate substance (CAS No.)	Lead(CAS: 7439-92-1)
SCIP	3aa24753-2852-4d33-bb59-09cca0fbf524

### EF3.1 Climate Change

CO2e kg	0.551 kg CO2e
---------	---------------

Phoenix Contact 2026 © - all rights reserved  
<https://www.phoenixcontact.com>

Phoenix Contact USA  
 586 Fulling Mill Road  
 Middletown, PA 17057, United States  
 (+717) 944-1300  
[info@phoenixcon.com](mailto:info@phoenixcon.com)