

TMC 7 B2/3 TERM - Terminal adapter



1022232

<https://www.phoenixcontact.com/us/products/1022232>

Please be informed that the data shown in this PDF document is generated from our online catalog. Please find the complete data in the user documentation. Our general terms of use for downloads are valid.

Feeder terminal adapter for TMC 72 or TMC 73 circuit breakers, two- or three-phase bus bars. Rated for 600 V AC/DC 115 A. Wire range 10...1/0 AWG. UL 508 Listed for connection to UL 1077 rated circuit breakers.



Product description

Feed-in terminal adapter for TMC 7 two- and three-pos. bus bars

Commercial data

Item number	1022232
Packing unit	1 pc
Minimum order quantity	1 pc
Sales key	CL09
Product key	CLA126
GTIN	4055626515908
Weight per piece (including packing)	39.53 g
Weight per piece (excluding packing)	31.2 g
Customs tariff number	85369010
Country of origin	DE

TMC 7 B2/3 TERM - Terminal adapter



1022232

<https://www.phoenixcontact.com/us/products/1022232>

Technical data

Product properties

Product type	Circuit breakers
Type	Adapter

Electrical properties

Rated voltage (III/3)	1000 V AC/DC
-----------------------	--------------

Connection data

Tightening torque, min	5.65 Nm
------------------------	---------

Dimensions

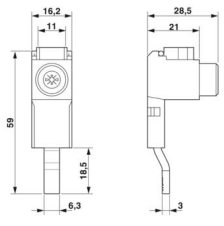
Dimensional drawing	
Width	16.2 mm
Height	28.5 mm

Material specifications

Color	light gray (RAL 7035)
	light gray (RAL 7035)

TMC 7 B2/3 TERM - Terminal adapter

1022232

<https://www.phoenixcontact.com/us/products/1022232>



Drawings

Dimensional drawing

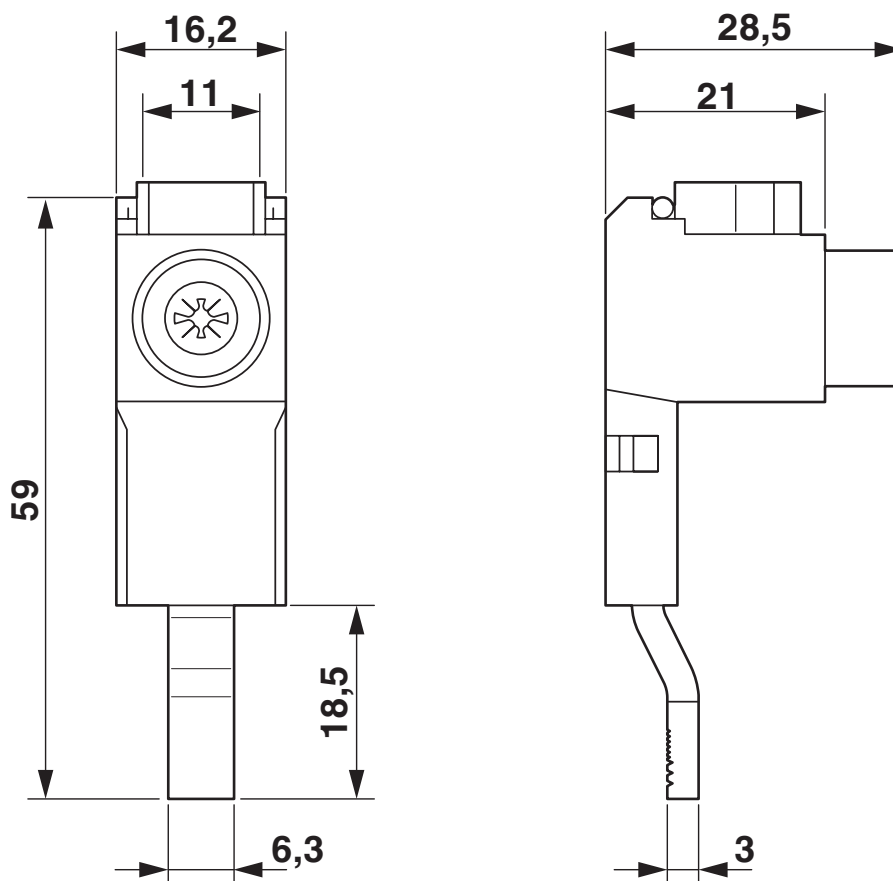

TMC 7 B2/3 TERM - Terminal adapter



1022232

<https://www.phoenixcontact.com/us/products/1022232>

Approvals

To download certificates, visit the product detail page: <https://www.phoenixcontact.com/us/products/1022232>



UL Listed

Approval ID: E123528



cUL Listed

Approval ID: E123528

TMC 7 B2/3 TERM - Terminal adapter



1022232

<https://www.phoenixcontact.com/us/products/1022232>

Classifications

ECLASS

ECLASS-13.0	27140492
ECLASS-15.0	27140492

ETIM

ETIM 10.0	EC002936
-----------	----------

UNSPSC

UNSPSC 21.0	39121400
-------------	----------

TMC 7 B2/3 TERM - Terminal adapter



1022232

<https://www.phoenixcontact.com/us/products/1022232>

Environmental product compliance

EU RoHS

Fulfills EU RoHS substance requirements	Yes, No exemptions
---	--------------------

China RoHS

Environment friendly use period (EFUP)	EFUP-E
	No hazardous substances above the limits

EU REACH SVHC

REACH candidate substance (CAS No.)	No substance above 0.1 wt%
-------------------------------------	----------------------------

EF3.1 Climate Change

CO2e kg	0.508 kg CO2e
---------	---------------

Phoenix Contact 2026 © - all rights reserved
<https://www.phoenixcontact.com>

Phoenix Contact USA
586 Fulling Mill Road
Middletown, PA 17057, United States
(+717) 944-1300
info@phoenixcon.com