

PTCM 0,5/ 7-PI-2,5 WH - PCB connector



1015247

<https://www.phoenixcontact.com/us/products/1015247>

Please be informed that the data shown in this PDF document is generated from our online catalog. Please find the complete data in the user documentation. Our general terms of use for downloads are valid.



The figure shows a 5-position version

PCB connector, nominal cross section: 0.75 mm², color: white, nominal current: 6 A, rated voltage (III/2): 160 V, contact connection type: Pin, number of potentials: 7, number of rows: 1, number of positions: 7, number of connections: 7, product range: PTCM 0,5/..-PI, pitch: 2.5 mm, connection method: Crimp connection, conductor/PCB connection direction: 0 °, plug-in system: COMBICON PTSM, locking: Snap-in locking, mounting method: Engagement nose, type of packaging: packed in cardboard

Your advantages

- White design: Stable color when welding and during use
- High current carrying capacity of 6 A in very compact dimensions
- Inverted connector with pin contacts for touch-proof device outputs or free-hanging cable/cable connections
- Cost-effective connection of crimped conductors in large quantities
- Tools for manual and automatic crimping available as an option

Commercial data

Item number	1015247
Packing unit	100 pc
Minimum order quantity	100 pc
Sales key	AA01
Product key	AAACP
GTIN	4055626496214
Weight per piece (including packing)	0.948 g
Weight per piece (excluding packing)	0.938 g
Customs tariff number	85389099
Country of origin	DE

PTCM 0,5/ 7-PI-2,5 WH - PCB connector



1015247

<https://www.phoenixcontact.com/us/products/1015247>

Technical data

Product properties

Product type	PCB connector
Product family	PTCM 0,5/...-PI
Product line	COMBICON Connectors XS
Number of positions	7
Pitch	2.5 mm
Number of connections	7
Number of rows	1
Number of potentials	7

Electrical properties

Properties

Nominal current I_N	6 A
Nominal voltage U_N	160 V
Contact resistance	3.2 m Ω
Rated voltage (III/3)	160 V
Rated surge voltage (III/3)	2.5 kV
Rated voltage (III/2)	160 V
Rated surge voltage (III/2)	2.5 kV
Rated voltage (II/2)	320 V
Rated surge voltage (II/2)	2.5 kV
Note on change in voltage	With a cable cross-section of AWG 18 or 0.75 mm ² , the rated insulation voltage is reduced to 63 V with a rated surge voltage of 1.5 kV and a pollution degree of 1 or 2, depending on the insulation thickness of the cable used.

Connection data

Connection technology

Type	Inverted
Connector system	COMBICON PTSM
Nominal cross section	0.75 mm ²
Contact connection type	Pin

Interlock

Locking type	Snap-in locking
Mounting type	Engagement nose

Conductor connection

Connection method	Crimp connection
Conductor/PCB connection direction	0 °
Conductor cross-section flexible	0.14 mm ² ... 0.75 mm ² (Maximum external diameter of the insulation 1.9 mm)

PTCM 0,5/ 7-PI-2,5 WH - PCB connector



1015247

<https://www.phoenixcontact.com/us/products/1015247>

Conductor cross-section AWG	26 ... 18 (Maximum external diameter of the insulation 1.9 mm)
Stripping length	4.1 mm ... 4.5 mm

Material specifications

Material data - housing

Color (Housing)	white (9010)
Insulating material	PA
Insulating material group	I
CTI according to IEC 60112	600
Flammability rating according to UL 94	V0
Glow wire flammability index GWFI according to EN 60695-2-12	850
Glow wire ignition temperature GWIT according to EN 60695-2-13	775
Temperature for the ball pressure test according to EN 60695-10-2	125 °C

Dimensions

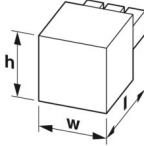
Dimensional drawing	
Pitch	2.5 mm
Width [w]	19.2 mm
Height [h]	5 mm
Length [l]	18.3 mm

Notes

Note on the contact	The information on the basic material and the finish properties of the crimp contacts is to be found in the E-Shop in the technical data for the respective crimp contact.
Note on application	All laboratory tests are performed in combination with the crimp contacts specified as accessories.
Note on application	The current depends on the crimp contact and conductor cross-section used.
Note on application	The corresponding crimp contacts are to be found in the "Accessories" tab.
Note on application	The crimp contacts may only be processed with approved crimping tools.
Note on the contact	These connectors conform to DIN EN 61984, connectors without switching power (COC). When used for their intended purpose, they must not be plugged in or disconnected live or under load.
Note on change in voltage	With a cable cross-section of AWG 18 or 0.75 mm ² , the rated insulation voltage is reduced to 63 V with a rated surge voltage of 1.5 kV and a pollution degree of 1 or 2, depending on the insulation thickness of the cable used.

Mechanical tests

Tensile strength of crimp connections

Result	Test passed
Conductor cross-section/conductor type/tractive force setpoint/actual value	0.14 mm ² / flexible / > 18 N

Insertion and withdrawal forces

Specification	IEC 60512-13-2:2006-02
Result	Test passed
No. of cycles	25
Insertion strength per pos. approx.	3 N
Withdraw strength per pos. approx.	2 N

Resistance of inscriptions

Specification	IEC 60068-2-70:1995-12
Result	Test passed

Polarization and coding

Specification	IEC 60512-13-5:2006-02
Result	Test passed

Visual inspection

Specification	IEC 60512-1-1:2002-02
Result	Test passed

Dimension check

Specification	IEC 60512-1-2:2002-02
Result	Test passed

Environmental and real-life conditions

Durability test

Specification	IEC 60512-9-1:2010-03
Impulse withstand voltage at sea level	2.95 kV
Contact resistance R ₁	3.2 mΩ
Contact resistance R ₂	3.4 mΩ
Insertion/withdrawal cycles	25
Insulation resistance, neighboring positions	> 5 MΩ

Climatic test

Specification	ISO 6988:1985-02
Corrosive stress	0.2 dm ³ SO ₂ on 300 dm ³ /40 °C/1 cycle
Thermal stress	105 °C/168 h
Power-frequency withstand voltage	1.39 kV

Vibration test

Specification	IEC 60068-2-6:2007-12
---------------	-----------------------

PTCM 0,5/ 7-PI-2,5 WH - PCB connector



1015247

<https://www.phoenixcontact.com/us/products/1015247>

Frequency	10 - 150 - 10 Hz
Sweep speed	1 octave/min
Amplitude	0.35 mm (10 Hz ... 60.1 Hz)
Acceleration	5g (60.1 Hz ... 150 Hz)
Test duration per axis	2.5 h
Test directions	X-, Y- and Z-axis

Shocks

Specification	IEC 60068-2-27:2008-02
Pulse shape	Semi-sinusoidal
Acceleration	30g
Shock duration	18 ms
Test directions	X-, Y- and Z-axis (pos. and neg.)

Railway application: Oscillation/broadband noise

Specification	DIN EN 50155 (VDE 0115-200):2018-05 IEC 61373:2010-05
Spectrum	Long life test category 1, class B, body mounted
Frequency	$f_1 = 5 \text{ Hz}$ to $f_2 = 150 \text{ Hz}$
ASD level	0.964 (m/s ²)/Hz
Acceleration	0.572 g
Test duration per axis	5 h
Test directions	X-, Y- and Z-axis
Contact interruption	< 1 μs
Result	Test passed

Railway application: Shocks

Specification	DIN EN 50155 (VDE 0115-200):2018-05 IEC 61373:2010-05
Pulse shape	Semi-sinusoidal
Acceleration	30g
Shock duration	18 ms
Number of shocks per direction	3
Test directions	X-, Y- and Z-axis (pos. and neg.)
Contact interruption	< 1 μs
Result	Test passed

Ambient conditions

Ambient temperature (storage/transport)	-40 °C ... 70 °C
Relative humidity (storage/transport)	30 % ... 70 %
Ambient temperature (assembly)	-5 °C ... 100 °C
Ambient temperature (operation)	-40 °C ... 105 °C (dependent on the derating curve)

Electrical tests

Thermal test | Test group C

PTCM 0,5/ 7-PI-2,5 WH - PCB connector



1015247

<https://www.phoenixcontact.com/us/products/1015247>

Specification	IEC 60512-5-1:2002-02
Tested number of positions	8

Insulation resistance

Specification	IEC 60512-3-1:2002-02
Insulation resistance, neighboring positions	> 5 MΩ

Air clearances and creepage distances |

Specification	IEC 60664-1:2007-04
Insulating material group	I
Comparative tracking index (IEC 60112)	CTI 600
Rated insulation voltage (III/3)	160 V
Rated surge voltage (III/3)	2.5 kV
minimum clearance value - non-homogenous field (III/3)	1.5 mm
minimum creepage distance (III/3)	2 mm
Rated insulation voltage (III/2)	160 V
Rated surge voltage (III/2)	2.5 kV
minimum clearance value - non-homogenous field (III/2)	1.5 mm
minimum creepage distance (III/2)	1.5 mm
Rated insulation voltage (II/2)	320 V
Rated surge voltage (II/2)	2.5 kV
minimum clearance value - non-homogenous field (II/2)	1.5 mm
minimum creepage distance (II/2)	1.6 mm

Packaging specifications

Type of packaging	packed in cardboard
-------------------	---------------------

Drawings

Diagram

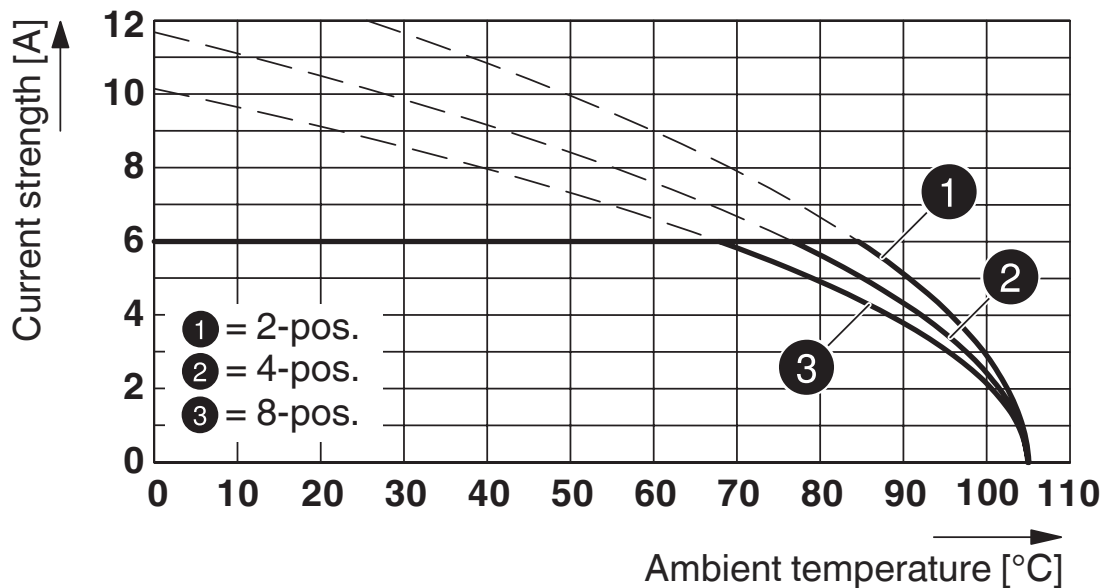

Type: PTCM 0,5/...-PL-2,5 WH with PTCM 0,5/...-PI-2,5 WH

Diagram

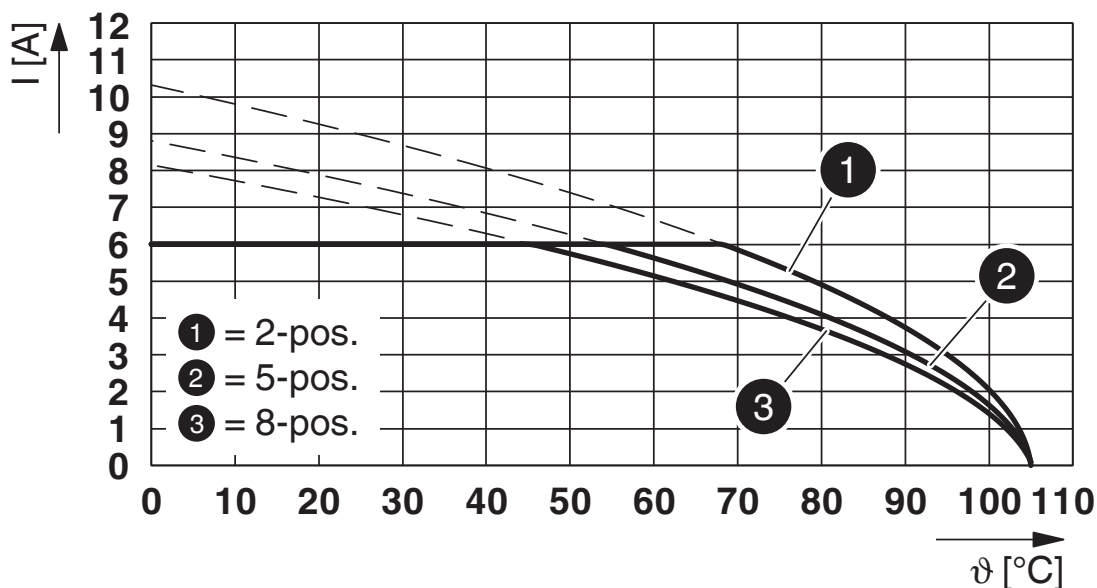

Type: PTCM 0,5/...-PI-2,5 WH with PTSM 0,5/...-HHI0-2,5-SMD WHR...

PTCM 0,5/ 7-PI-2,5 WH - PCB connector





1015247

<https://www.phoenixcontact.com/us/products/1015247>

Approvals

To download certificates, visit the product detail page: <https://www.phoenixcontact.com/us/products/1015247>

 cULus Recognized Approval ID: E60425-20101209				
	Nominal voltage U_N	Nominal current I_N	Cross section AWG	Cross section mm^2
B	150 V	5 A	22 - 18	-
D	150 V	5 A	22 - 18	-

 VDE approval of drawings Approval ID: 40048497				
	Nominal voltage U_N	Nominal current I_N	Cross section AWG	Cross section mm^2
keine	160 V	6 A	-	0.14 - 0.75

PTCM 0,5/ 7-PI-2,5 WH - PCB connector



1015247

<https://www.phoenixcontact.com/us/products/1015247>

Classifications

ECLASS

ECLASS-13.0	27460202
ECLASS-15.0	27460202

ETIM

ETIM 10.0	EC002638
-----------	----------

UNSPSC

UNSPSC 21.0	39121400
-------------	----------

PTCM 0,5/ 7-PI-2,5 WH - PCB connector



1015247

<https://www.phoenixcontact.com/us/products/1015247>

Environmental product compliance

EU RoHS

Fulfills EU RoHS substance requirements	Yes, No exemptions
---	--------------------

China RoHS

Environment friendly use period (EFUP)	EFUP-E
	No hazardous substances above the limits

EU REACH SVHC

REACH candidate substance (CAS No.)	No substance above 0.1 wt%
-------------------------------------	----------------------------

EF3.1 Climate Change

CO2e kg	0.019 kg CO2e
---------	---------------

Phoenix Contact 2026 © - all rights reserved
<https://www.phoenixcontact.com>

Phoenix Contact USA
586 Fulling Mill Road
Middletown, PA 17057, United States
(+717) 944-1300
info@phoenixcon.com