

ECP 10 - Electronic circuit breaker



0912020

<https://www.phoenixcontact.com/us/products/0912020>

Please be informed that the data shown in this PDF document is generated from our online catalog. Please find the complete data in the user documentation. Our general terms of use for downloads are valid.



Electronic circuit breaker, 1-position, connection method: pluggable, tripping characteristic: electronic, fuse type: Automatic device, mounting type: on base element

Your advantages

- System safety is increased during maintenance work thanks to disconnection via electrical isolation
- Error-free short-circuit detection even across long cable paths with the electronics characteristic curve
- Active current limitation to improve the capacity of the upstream power supply

Commercial data

Item number	0912020
Packing unit	1 pc
Sales key	CL04
Product key	CLA132
GTIN	4046356014359
Weight per piece (including packing)	77.4 g
Weight per piece (excluding packing)	74.78 g
Customs tariff number	85362010
Country of origin	DE

ECP 10 - Electronic circuit breaker



0912020

<https://www.phoenixcontact.com/us/products/0912020>

Technical data

Product properties

Product type	Device circuit breakers
Product family	ECP
Type	Male
Number of positions	1
Number of rows	1
No. of channels	1

Insulation characteristics

Overvoltage category	II
Degree of pollution	2

Electrical properties

Fuse type	Automatic device
Switch-on delay	300.00 ms
Short-circuit current	Active current limitation, max. $1.8 \times I_N$
Service life electrical	10000 cycles in the case of $1 \times I_N$
Switching capacity I_{CN}	Active current limitation
Fuse	electronic

General

Operating voltage	24 V DC
	18 V DC ... 32 V DC
Nominal current I_N	10 A
Rated surge voltage	0.5 kV
Tripping method	E (electronic)
Required backup fuse	not required, integrated failsafe element
Dielectric strength	1000 V AC (Actuation area)
	500 V AC (Installation area)
	500 V AC (Load circuit signal contact)
Switch off	typ. $1.5 \times I_N$
Active current limitation	active
Fuse	electronic
Closed circuit current I_0	typ. 13 mA
Voltage drop	280 mV (at I_N)
Contact switching type	With electrical isolation

Load circuit

Shutdown time	typ. 5 s (for electrical insulation when $I_{Load} > 1.1 \times I_N$)
Max. capacitive load	20000 μ F
Switch-on delay	typ. 0.3 s

Auxiliary contact

ECP 10 - Electronic circuit breaker



0912020

<https://www.phoenixcontact.com/us/products/0912020>

Contact connection type	floating signal contact
Minimum operating voltage U_{\min} DC	10 V DC
Maximum operating voltage U_{\max} DC	30 V DC
Minimum operating current I_{\min}	10 mA
Max. operating current I_{\max}	0.5 A

Connection data

Connection method	pluggable
-------------------	-----------

Dimensions

Width	12.5 mm
Height	60 mm
Height NS 35/15	151.5 mm
Height NS 35/7,5	144 mm
Depth	70 mm
Complete module width	38 mm
Complete module height	115 mm
Complete module depth	147.5 mm

Material specifications

Flammability rating according to UL 94	V0
Insulating material group	IIIa
Insulating material	PPS

Environmental and real-life conditions

Ambient conditions

Degree of protection	IP30 (Actuation area)
Ambient temperature (operation)	0 °C ... 50 °C (non-condensing)
Ambient temperature (storage/transport)	-20 °C ... 70 °C
Humidity test	96 h, 95 % RH, 40 °C

Mounting

Mounting type	on base element
---------------	-----------------

ECP 10 - Electronic circuit breaker

0912020

<https://www.phoenixcontact.com/us/products/0912020>

Drawings

Functional drawing

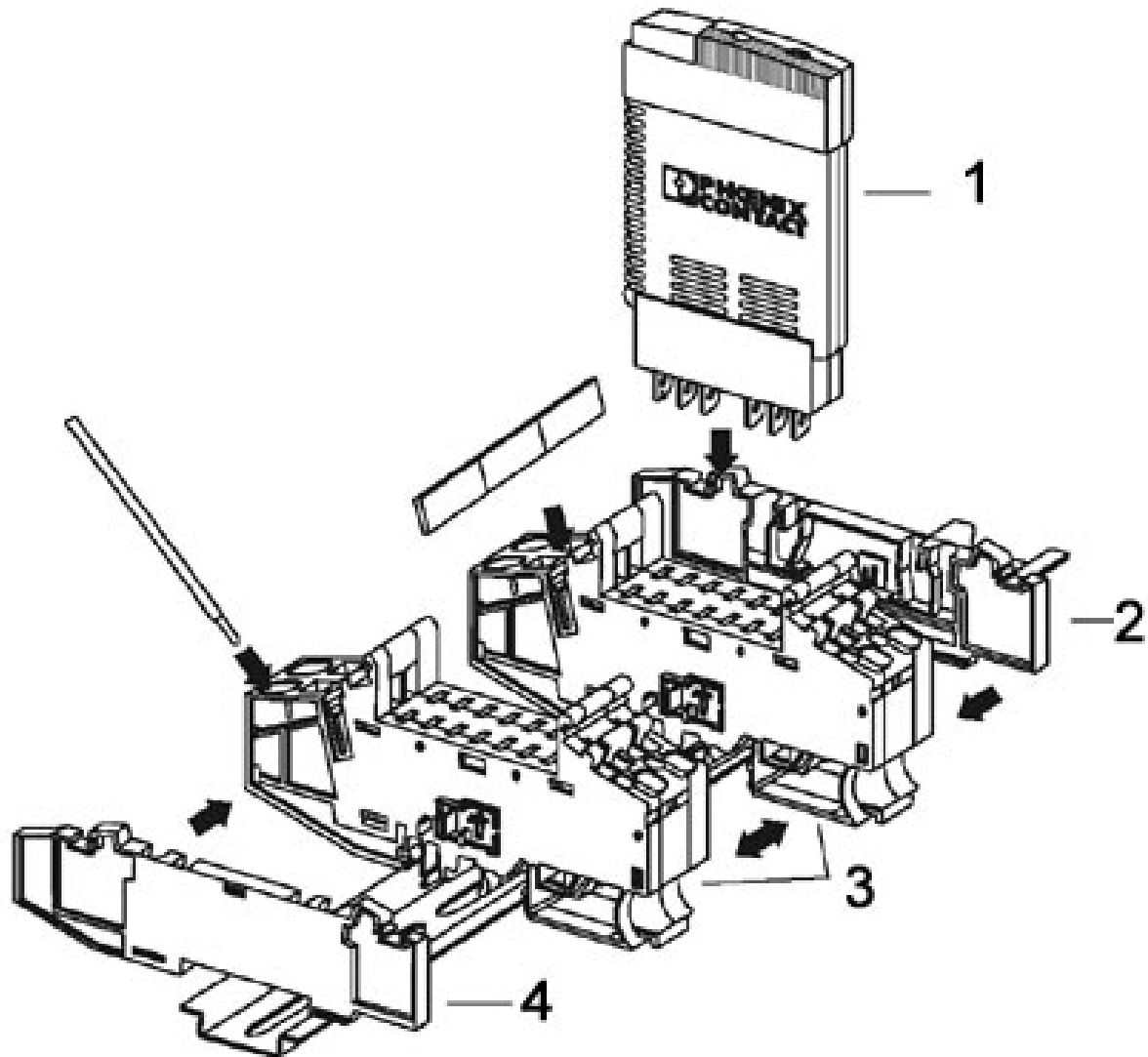

- 1 = Selective circuit breaker
- 2 = Socket termination element
- 3 = Modular socket element
- 4 = Socket termination element

Diagram

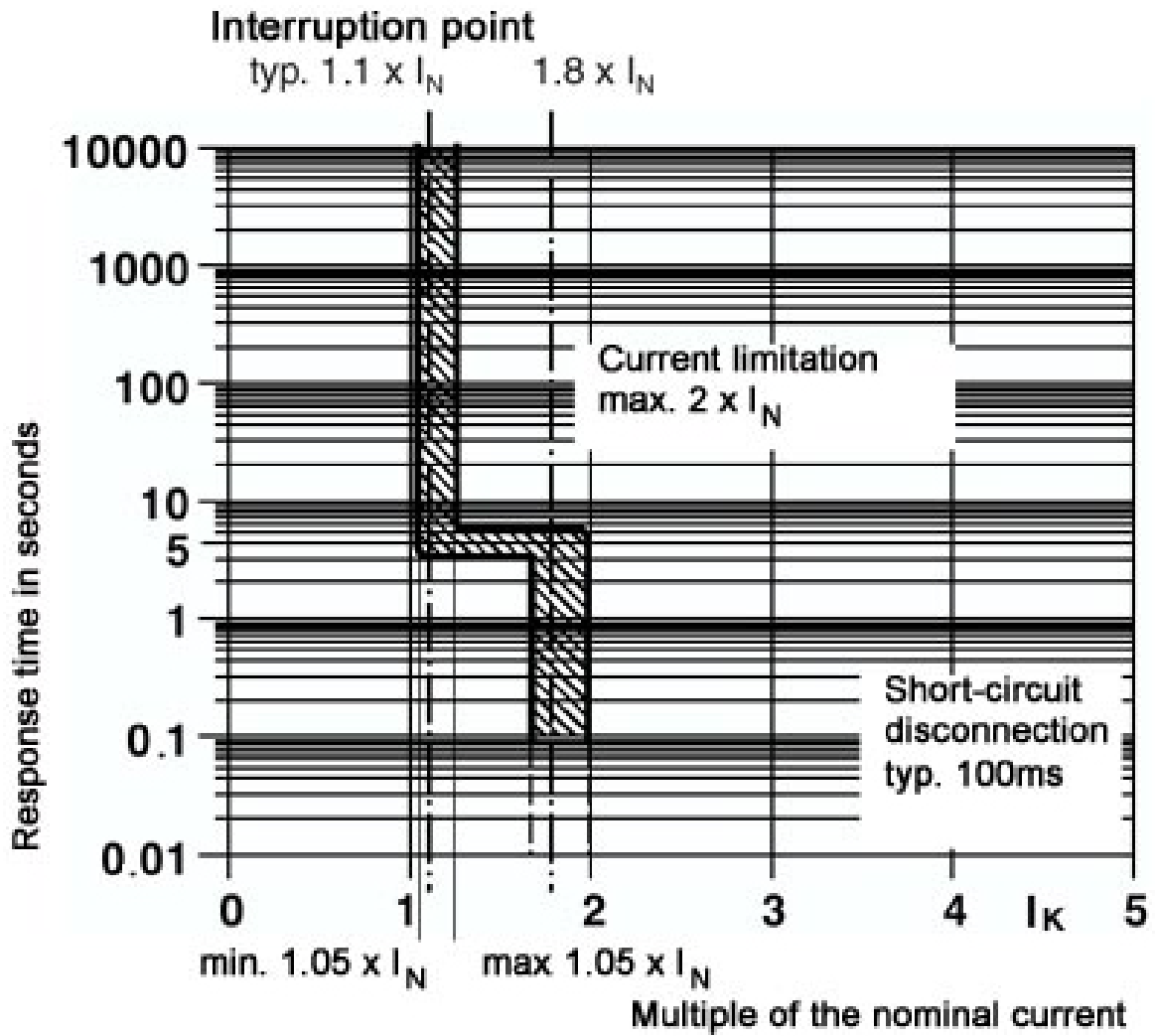

ECP 10 - Electronic circuit breaker

0912020

<https://www.phoenixcontact.com/us/products/0912020>

Circuit diagram

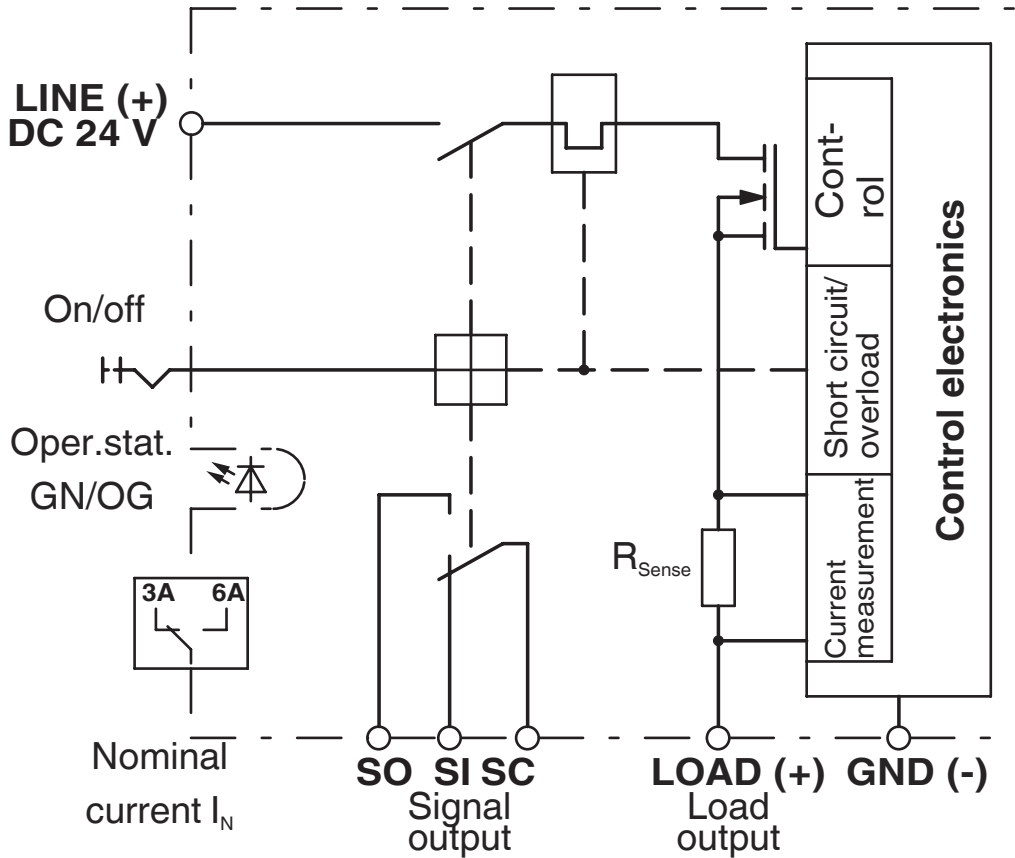

Block diagram

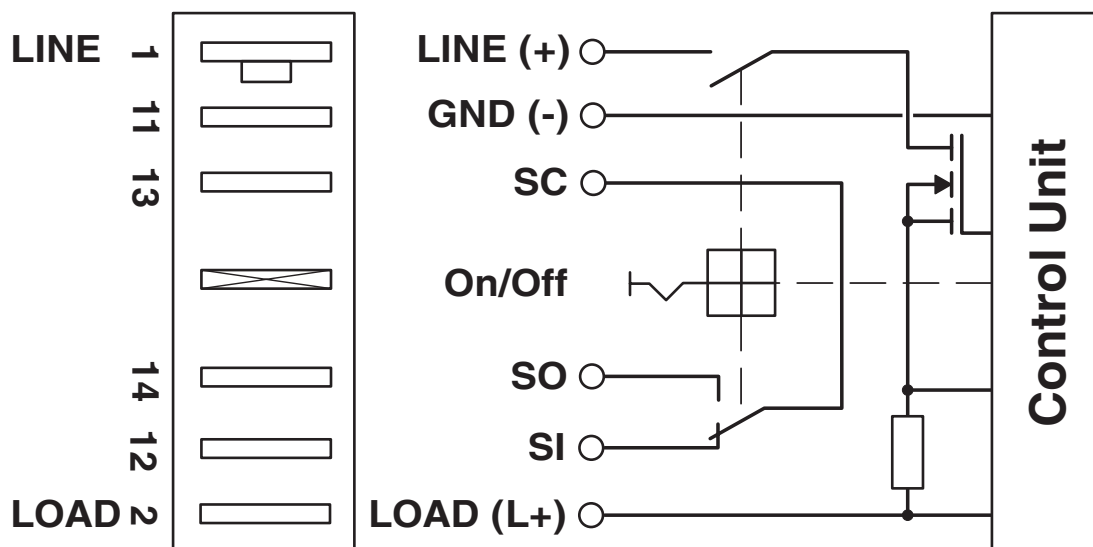

ECP 10 - Electronic circuit breaker



0912020

<https://www.phoenixcontact.com/us/products/0912020>

Classifications

UNSPSC

UNSPSC 21.0	39121410
-------------	----------

ECP 10 - Electronic circuit breaker



0912020

<https://www.phoenixcontact.com/us/products/0912020>

Environmental product compliance

EU RoHS

Fulfills EU RoHS substance requirements	Yes
Exemption	6(c), 7(a)

China RoHS

Environment friendly use period (EFUP)	EFUP-50
	An article-related China RoHS declaration table can be found in the download area for the respective article under "Manufacturer declaration". For all articles with EFUP-E, no China RoHS declaration table issued and required.

EU REACH SVHC

REACH candidate substance (CAS No.)	Lead(CAS: 7439-92-1)
-------------------------------------	----------------------

Phoenix Contact 2026 © - all rights reserved
<https://www.phoenixcontact.com>

Phoenix Contact USA
586 Fulling Mill Road
Middletown, PA 17057, United States
(+717) 944-1300
info@phoenixcon.com