

Secure teleservice solution minimizes downtimes of rotary transfer machines



PHOENIX CONTACT PTY Ltd
Unit 7, 2-8 South Street
Rydalmere NSW 2116
Fax: 1300 723 399
Customer Service Hotline
1300 786 411



Secure teleservice solution minimizes downtimes of rotary transfer machines

Overview

- When it comes to ensuring smooth production processes with high availability, 24 hour service from the machine builder is essential.
- Secure remote access to the system installed at the end user's premises is a fundamental aspect of the service concept.
- The FL mGuard RS4000 TX/TX VPN security router from Phoenix Contact acts as the core element of the new remote maintenance concept in Pfiffner's processing centers.

Customer profile

The rotary transfer machines developed by K.R. Pfiffner GmbH produce more than 300,000 workpieces each year which can be up to the size of a fist.

The processing centers, which are used for mass production of precision parts for the automotive industry, for example, are manufactured by 450 people around the world.



Rotary transfer machine from Pfiffner for mass production of precision parts

Application

To ensure smooth production processes with high availability, 24 hour service from the machine builder is essential. This is the only way to ensure that the relevant measures are taken in the event of an error so that the processing centers are only out of action for a short period of time. Secure remote access to the system installed at the end user's premises is a fundamental aspect of the service concept.

“Initially, remote maintenance was carried out using analog modem connections. However, their performance no longer satisfied our requirements. We also experienced frequent connection problems,” states Tobias Halbritter, who looks after the remote maintenance system at Pfiffner and is largely responsible for the implemented structure based on secure VPN connections (Virtual Private Network).



Tobias Halbritter, responsible for machine IT and software development at Pfiffner

Solution

The FL mGuard RS4000 TX/TX VPN security router from Phoenix Contact, which is installed in the processing centers, acts as the core element of the new remote maintenance concept. “As we were already using the mGuard technology with installed firewall to connect our system to the customer network, we are now also using the device for secure remote access,” explains Halbritter. For service technicians, the VPN connection makes it seem almost as if they are sitting directly in front of the system. This shortens maintenance response times. What is more, on-site deployment is often no longer needed, resulting in significant savings in maintenance costs.

The user initiates the establishment of the IPsec tunnel to the Pfiffner Remote Services Center by actuating a key switch. The service technician then has access to the system. The system operator thus maintains control over any access to the application. FL MGUARD's optional external configuration memory is also helpful in this regard. Since Pfiffner employees often do not know the IP parameters of the customer network before machine delivery, the respective configuration can simply be transmitted via SD card later.



The security router ensures secure VPN connections

The VPN hub is deliberately not integrated into the Pfiffner corporate network, but is operated as a portal system with its own Internet access. This means that Pfiffner can also provide external suppliers with secure access to parts of the relevant customer system without tunneling these through their own communication network.

From the perspective of network technology, the customer systems are usually configured with identical address ranges so that individual system parts are always accessed with the same IP address. To ensure that no address conflict occurs whenever several rotary transfer machines are to be serviced at the same time, the addresses must be virtualized or depicted in separate address ranges. This requirement is implemented in the mGuard routers by 1:1 NAT (Network Address Translation) in the VPN tunnel.

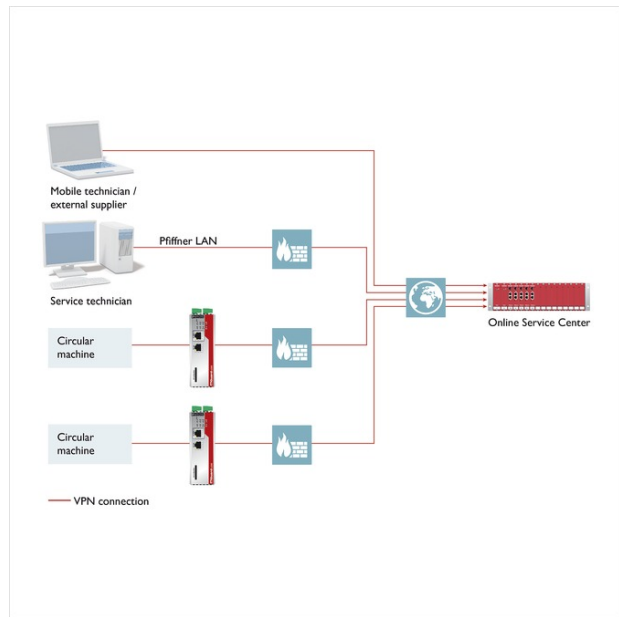

Portal structure of the remote maintenance system

Summary

The use of Internet-based remote maintenance with secure VPN connections benefits both the manufacturer as well as the operators of Pfiffner processing centers. In addition to a quicker response in the event of an error, the advantages include direct access to the system, which minimizes downtimes as well as reducing service costs as there is no longer a need for costly on-site visits. These are criteria which play a decisive role, particularly when it comes to mass production with rotary transfer machines.