

# ELR H3-IS-SC- 24DC/500AC-9-P - Hybrid motor starter



2908698

<https://www.phoenixcontact.com/gb/products/2908698>

Please be informed that the data shown in this PDF document is generated from our online catalog. Please find the complete data in the user documentation. Our general terms of use for downloads are valid.



Hybrid motor starter as an alternative to a conventional protective circuit. Starts 3~ AC motors up to 9 A, provides motor protection and emergency stop up to SIL 3/PL e. Group shut-down, supply, and relay extension possible via DIN rail connector.

## Product description

The modular 3-phase hybrid motor starter with direct start function and current monitoring provides the following functions: - Forward running - Motor overload protection - Emergency stop to performance level PLe (TÜV certified) Additional advantages are provided by using the DIN rail connector adapter (Item No. 2203861): - Emergency stop of the enable signal is also possible via the DIN rail connector, e.g. via a safety relay (PSR DC38...) - Power can also be supplied via the DIN rail connector by a system power supply (e. g., QUINT4-SYS...) or via the PCB connector IMC 1,5/ 5-ST-3,81, Item No. 1857919 - Optional relay module (e. g., EM-2RSC/21AU-R/L-P, Item No. 2908701) provides additional status information

## Commercial data

Item number	2908698
Packing unit	1 pc
Minimum order quantity	1 pc
Note	Made to order (non-returnable)
Sales key	DK7413
Product key	DK7413
GTIN	4055626323152
Weight per piece (including packing)	325.8 g
Weight per piece (excluding packing)	306 g
Customs tariff number	85371098
Country of origin	DE

# ELR H3-IS-SC- 24DC/500AC-9-P - Hybrid motor starter



2908698

<https://www.phoenixcontact.com/gb/products/2908698>

## Technical data

### Product properties

Product type	Hybrid motor starters
Product family	CONTACTRON
Operating mode	100% operating factor

### Electrical properties

Number of phases	3
Motor starter type	Direct starter
Switching frequency	≤ 2 Hz (Load-dependent)
Switching frequency	≤ 2 Hz (Load-dependent)
Maximum power dissipation	7 W
Minimum power dissipation	0.88 W
Coordination type	1

### Supply

Rated control circuit supply voltage $U_S$	24 V DC
Control supply voltage range	19.2 V DC ... 30 V DC
Rated control supply current $I_S$	60 mA
Protective circuit	Surge protection Reverse polarity protection; Parallel polarity protection diode

### Insulation characteristics

Rated insulation voltage	550 V
Rated surge voltage	6 kV
Overvoltage category	III
Degree of pollution	2
Insulation characteristics between the control input and control supply voltage, and auxiliary circuit to the main circuit	Safe isolation (IEC 60947-1)
Isolation characteristics between the control input and control supply voltage to auxiliary circuit	Safe isolation (IEC 60947-1) in the auxiliary circuit ≤ 300 V AC

### Emergency tripping

Operate threshold	> 60 A
Response time	< 0.5 s

### Input data

#### Control

Input name	Control input and enable input
Note	The enable input is compatible with signals with blanking (semiconductor output signals with test pulse with max. 3 ms duration), unblanking pulses of max. 4 ms are tolerated without adversely affecting the safety function.
Rated actuating voltage $U_C$	24 V DC

# ELR H3-IS-SC- 24DC/500AC-9-P - Hybrid motor starter



2908698

<https://www.phoenixcontact.com/gb/products/2908698>

Triggering voltage range	19.2 V DC ... 30 V DC
Rated actuating current $I_C$	7 mA
Switching threshold	9.6 V ("0" signal) 19.2 V ("1" signal)
Switching level	< 5 V DC (For EMERGENCY STOP)
Typical turn-off time	< 30 ms
Protective circuit	Reverse polarity protection

## Output data

### AC output

Rated operating voltage $U_e$	500 V AC
Operating voltage range	42 V AC ... 550 V AC
Rated operating current $I_e$	9 A (AC-51) 7 A (AC-53a)
Mains frequency	50/60 Hz
Load current range	1.5 A ... 9 A
Trigger characteristic in acc. with IEC 60947-4-2	Class 10 ( $\leq 3$ A) Class 10A ( $> 3$ A)
Cooling time	20 min (for auto reset)
Leakage current	0 mA

### Acknowledge output

Note	Confirmation: floating change-over contact, signal contact
Contact switching type	1 changeover contact
Switching capacity in accordance with IEC 60947-5-1	2 A (24 V (DC13))

## Connection data

### Control circuits

Connection method	Screw connection
Stripping length	8 mm
Screw thread	M3
Conductor cross-section rigid	0.2 mm <sup>2</sup> ... 2.5 mm <sup>2</sup>
Conductor cross-section flexible	0.2 mm <sup>2</sup> ... 2.5 mm <sup>2</sup>
Conductor cross-section AWG	24 ... 14
Tightening torque	0.5 Nm ... 0.6 Nm 5 lb <sub>f</sub> -in. ... 7 lb <sub>f</sub> -in.

### Load circuit

Connection method	Screw connection
Stripping length	8 mm
Screw thread	M3
Conductor cross-section rigid	0.2 mm <sup>2</sup> ... 2.5 mm <sup>2</sup>
Conductor cross-section flexible	0.2 mm <sup>2</sup> ... 2.5 mm <sup>2</sup>
Conductor cross-section AWG	24 ... 14

# ELR H3-IS-SC- 24DC/500AC-9-P - Hybrid motor starter



2908698

<https://www.phoenixcontact.com/gb/products/2908698>

Tightening torque	0.5 Nm ... 0.6 Nm
	5 lb <sub>F</sub> in. ... 7 lb <sub>F</sub> in.

## Signaling

Status display	LED (yellow)
Operating voltage display	Green LED
Error indication	Red LED

## Dimensions

Width	22.5 mm
Height	107 mm
Depth	114 mm

## Material specifications

Flammability rating according to UL 94 (Housing)	V0 (Housing)
--	--------------

## Environmental and real-life conditions

### Ambient conditions

Degree of protection	IP20
Ambient temperature (operation)	-25 °C ... 70 °C (observe derating)
Ambient temperature (storage/transport)	-40 °C ... 80 °C
Altitude	≤ 2000 m

## Approvals

### UL approval

Certificate	NLDX.E228652
	NRNT.E172140

### Safety Integrity Level (SIL, IEC 61508)

Identification	≤ 3
Note	Safe shutdown

### Safety Integrity Level (SIL, IEC 61508)

Identification	2
Note	Motor protection

### Performance Level (ISO 13849)

Identification	≤ e
Note	Safe shutdown

### Category (ISO 13849)

Identification	≤ 3
Note	Safe shutdown

### UL data

SCCR	100 kA (480 V AC (fuse: 30 A class CC/30 A class J (high fault)))
------	---

# ELR H3-IS-SC- 24DC/500AC-9-P - Hybrid motor starter



2908698

<https://www.phoenixcontact.com/gb/products/2908698>

	5 kA (480 V AC (fuse: 20 A RK5 (standard fault)))
FLA	7.6 A (480 V AC)
Group installation	20 A (class RK5, SCCR 5kA (480 V AC), #24 - 14 AWG max. solid and stranded)
	30 A (class CC or J, SCCR 100kA (480 V AC), #24 - 14 AWG max, solid and stranded)
Category code	NLDX / NRNT
Horsepower ratings	2 hp (208 V AC)
	2 hp (230 V AC)
	2 hp (240 V AC)
	5 hp (480 V AC)
Ambient temperature (operation)	-25 °C ... 55 °C

## Standards and regulations

### Standards/regulations

Standards/regulations	EN 60947-1
	EN 60947-4-2
	EN ISO 13849
	IEC 62061
	IEC 61508

## Mounting

Mounting type	DIN rail mounting
Assembly note	alignable, for spacing see derating
Mounting position	vertical (horizontal DIN rail, motor output below)

# ELR H3-IS-SC- 24DC/500AC-9-P - Hybrid motor starter

2908698

<https://www.phoenixcontact.com/gb/products/2908698>

## Drawings

Block diagram

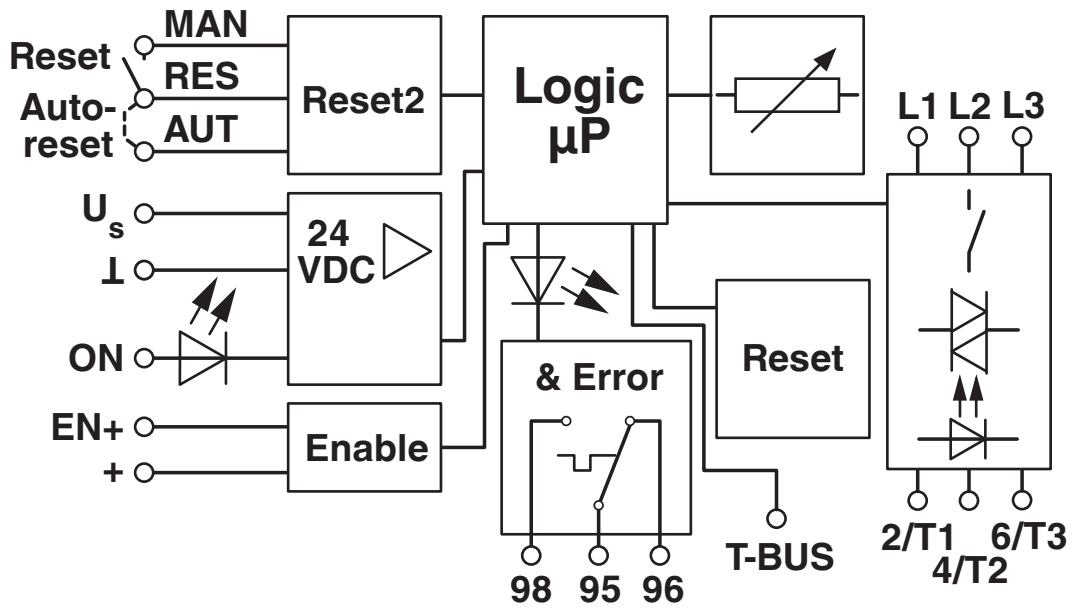

# ELR H3-IS-SC- 24DC/500AC-9-P - Hybrid motor starter



2908698

<https://www.phoenixcontact.com/gb/products/2908698>

## Classifications

### ECLASS

ECLASS-13.0

27370905

### ETIM

ETIM 9.0

EC001037

### UNSPSC

UNSPSC 21.0

25173900

# ELR H3-IS-SC- 24DC/500AC-9-P - Hybrid motor starter



2908698

<https://www.phoenixcontact.com/gb/products/2908698>

## Environmental product compliance

### EU RoHS

Fulfills EU RoHS substance requirements	Yes
Exemption	7(a), 7(c)-I

### China RoHS

Environment friendly use period (EFUP)	EFUP-50
	An article-related China RoHS declaration table can be found in the download area for the respective article under "Manufacturer declaration". For all articles with EFUP-E, no China RoHS declaration table issued and required.

### EU REACH SVHC

REACH candidate substance (CAS No.)	Lead(CAS: 7439-92-1)
SCIP	6d88e233-c02d-4189-aa14-dac3b0210a52

Phoenix Contact 2026 © - all rights reserved  
<https://www.phoenixcontact.com>

PHOENIX CONTACT Ltd  
Halesfield 13, Telford  
Shropshire, TF7 4PG  
01952 681700  
[info@phoenixcontact.co.uk](mailto:info@phoenixcontact.co.uk)