

EMM 3-24DC/500AC-160-EXM-IFS - Motor management



2908603

<https://www.phoenixcontact.com/gb/products/2908603>

Please be informed that the data shown in this PDF document is generated from our online catalog. Please find the complete data in the user documentation. Our general terms of use for downloads are valid.

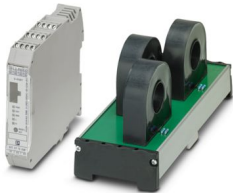

Electronic machine management for operation with an external current transformer (160 A) - precise energy measurement and active power measurement of motors, machines, and other 3-phase loads. Freely configurable switching/signaling thresholds. Order cables separately.

Product description

Electronic machine management for operation with external current transformers (160 A) – Precise energy measurement, real power measurement, current and voltage measurement of motors, machines or other 3-phase loads. Freely parameterizable switching and signaling thresholds. As an option, can be networked with all common fieldbus systems via a gateway.

Commercial data

Item number	2908603
Packing unit	1 pc
Minimum order quantity	1 pc
Note	Made to order (non-returnable)
Sales key	DK7522
Product key	DK7522
GTIN	4055626311784
Weight per piece (including packing)	1,050 g
Weight per piece (excluding packing)	1,115.7 g
Customs tariff number	85371098
Country of origin	DE

EMM 3-24DC/500AC-160-EXM-IFS - Motor management



2908603

<https://www.phoenixcontact.com/gb/products/2908603>

Technical data

Product properties

Product type	Electronic motor manager
Product family	CONTACTRON
Operating mode	100% operating factor

Electrical properties

Number of phases	3
Maximum power dissipation for nominal condition	2.5 W

Supply

Rated control circuit supply voltage U_S	24 V DC
Control supply voltage range	19.2 V DC ... 30 V DC
Rated control supply current I_S	< 33 mA

Insulation characteristics

Rated insulation voltage	500 V
Rated surge voltage	6 kV
Overvoltage category	III
Degree of pollution	2

Input data

Digital inputs

Number of inputs	4 (IN1 - IN4)
Rated actuating voltage U_C	24 V DC
Triggering voltage range	19.2 V DC ... 30 V DC
Rated actuating current I_C	3.3 mA
Switching threshold	9.6 V ("0" signal) 19.2 V ("1" signal)

Supply for digital outputs

Nominal supply voltage	24 V DC
Nominal supply voltage range	19.2 V DC ... 30 V DC

Power measurement

Basic accuracy	typ. 0.25 % (Tu= 20 °C, U= 400 V, Cos Phi= 0,8)
Power range	350 W ... 111 kW (400 V AC)

Voltage measurement/star voltage

Basic accuracy	typ. 0.5 %
Voltage range	42 V AC ... 550 V AC

Current measurement

Basic accuracy	typ. 0.5 %
Current range	0.5 A ... 160 A

EMM 3-24DC/500AC-160-EXM-IFS - Motor management



2908603

<https://www.phoenixcontact.com/gb/products/2908603>

Measuring via	External push-through current transformers connected upstream
---------------	---

Output data

Output name	Acknowledging contacts O1-O4
Note	The meaning of the acknowledgement outputs can be freely parameterized, see user manual
Number of outputs	4
Nominal output voltage	24 V DC (semiconductor output)
Output voltage range	19.2 V DC ... 30 V DC
Continuous load current	500 mA
Residual voltage	< 100 mV
Protective circuit	Suppressor diode
Surge voltage protection	> 33 V DC

Connection data

Control circuits

Connection method	Screw connection
Stripping length	8 mm
Screw thread	M3
Conductor cross-section rigid	0.14 mm ² ... 2.5 mm ²
Conductor cross-section flexible	0.14 mm ² ... 2.5 mm ²
Conductor cross-section AWG	26 ... 12
Tightening torque	0.5 Nm ... 0.6 Nm (5-7 lbs-in)

Load circuit

Connection method	Screw connection
Stripping length	8 mm
Screw thread	M3
Conductor cross-section rigid	0.14 mm ² ... 2.5 mm ²
Conductor cross-section flexible	0.14 mm ² ... 2.5 mm ²
Conductor cross-section AWG	26 ... 12
Tightening torque	0.5 Nm ... 0.6 Nm (5-7 lbs-in)

Signal connection on electronic management module (EMM)

Connection method	D-SUB pin strip
Number of connections	1
Number of positions	9

Signal connection on current transformer module

Connection method	D-SUB socket strip
Number of connections	1
Number of positions	9

Signaling

Status display	LED (yellow)
----------------	--------------

EMM 3-24DC/500AC-160-EXM-IFS - Motor management



2908603

<https://www.phoenixcontact.com/gb/products/2908603>

Operating voltage display	Green LED
Error indication	Red LED
Data communication display	green LED

Dimensions

Width	22.5 mm
Width Current transformer	177 mm
Height	99 mm
Height Current transformer	75 mm
Depth	114.5 mm
Depth Current transformer	88 mm
Diameter	23 mm

Current transformer

Designation	Ext 160 CT
Width	177 mm
Height	75 mm
Depth	88 mm
Primary round conductor (diameter)	23 mm

Material specifications

Color	gray (RAL 7042)
-------	-----------------

Environmental and real-life conditions

Ambient conditions

Degree of protection	IP20
Ambient temperature (operation)	-25 °C ... 70 °C
Ambient temperature (storage/transport)	-40 °C ... 80 °C

Approvals

UKCA

Certificate	UKCA-compliant
-------------	----------------

Standards and regulations

Standards/regulations

Standards/regulations	EN 60947-1
	EN 60947-4-2
	EN 61000-6-2
	EN 61000-6-3

Mounting

Mounting type	DIN rail mounting
Assembly note	in rows with zero spacing
Mounting position	any

EMM 3-24DC/500AC-160-EXM-IFS - Motor management

2908603

<https://www.phoenixcontact.com/gb/products/2908603>

Drawings

Block diagram

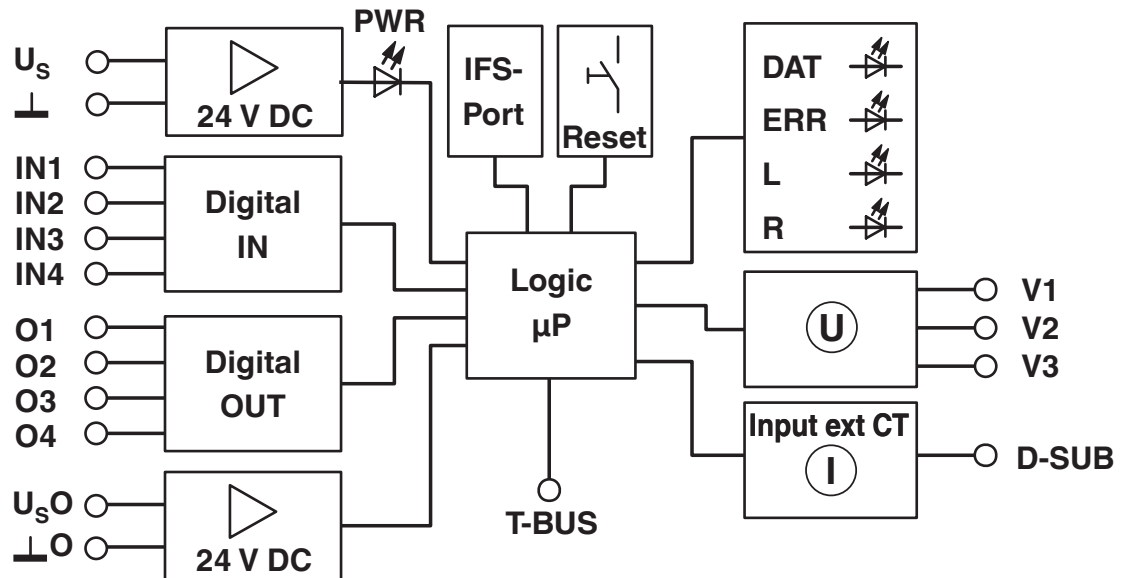

EMM 3-24DC/500AC-160-EXM-IFS - Motor management



2908603

<https://www.phoenixcontact.com/gb/products/2908603>

Approvals

To download certificates, visit the product detail page: <https://www.phoenixcontact.com/gb/products/2908603>



EAC

Approval ID: RU*C-DE.*08.B.00520*



UL Listed

Approval ID: E140324



cUL Listed

Approval ID: E140324

EMM 3-24DC/500AC-160-EXM-IFS - Motor management



2908603

<https://www.phoenixcontact.com/gb/products/2908603>

Classifications

ECLASS

ECLASS-13.0

27370804

ETIM

ETIM 9.0

EC002572

UNSPSC

UNSPSC 21.0

39121100

EMM 3-24DC/500AC-160-EXM-IFS - Motor management



2908603

<https://www.phoenixcontact.com/gb/products/2908603>

Environmental product compliance

EU RoHS

Fulfills EU RoHS substance requirements	Yes
Exemption	6(c), 7(a), 7(c)-I

China RoHS

Environment friendly use period (EFUP)	EFUP-50
	An article-related China RoHS declaration table can be found in the download area for the respective article under "Manufacturer declaration". For all articles with EFUP-E, no China RoHS declaration table issued and required.

EU REACH SVHC

REACH candidate substance (CAS No.)	Lead(CAS: 7439-92-1)
SCIP	bfaa1548-ddd3-4961-aeac-1d7cdfdc222c

Phoenix Contact 2026 © - all rights reserved

<https://www.phoenixcontact.com>

PHOENIX CONTACT Ltd
Halesfield 13, Telford
Shropshire, TF7 4PG
01952 681700
info@phoenixcontact.co.uk