

# ELR H5-I-PT- 24DC/500AC-9 - Hybrid motor starter



2903912

<https://www.phoenixcontact.com/gb/products/2903912>

Please be informed that the data shown in this PDF document is generated from our online catalog. Please find the complete data in the user documentation. Our general terms of use for downloads are valid.



Hybrid motor starter for reversing 3~ AC motors up to 500 V AC and 9 A output current, with 24 V DC control voltage, adjustable overload shutdown, and push-in connection.

## Your advantages

- 22.5 mm wide
- Reduction in wiring
- Space saving
- Long service life
- 3-phase loop bridges
- Adjustable current for bimetal function
- Low-wear switching

## Commercial data

Item number	2903912
Packing unit	1 pc
Minimum order quantity	1 pc
Note	Made to order (non-returnable)
Sales key	DK7424
Product key	DK7424
GTIN	4046356771351
Weight per piece (including packing)	242.2 g
Weight per piece (excluding packing)	289.2 g
Customs tariff number	85371098
Country of origin	DE

## Technical data

### Notes

Notes on operation	If this device is to be used in combination with the CrossPowerSystem power distribution board, the device mount for the 16 A fuse (order designation: EM-CPS-DA-22,5F/16A; order number: 1002668) is required in order to attach the hybrid motor starter to the power distribution board.
--------------------	---

### Product properties

Product type	Hybrid motor starters
Product family	CONTACTRON
Operating mode	100% operating factor

### Electrical properties

Number of phases	3
Motor starter type	Reversing starter
Switching frequency	≤ 2 Hz (Load-dependent)
Maximum power dissipation for nominal condition	13.5 W
Switching frequency	≤ 2 Hz (Load-dependent)
Maximum power dissipation	14.6 W
Minimum power dissipation	1.1 W
Coordination type	1

### Supply

Rated control circuit supply voltage $U_S$	24 V DC
Control supply voltage range	19.2 V DC ... 30 V DC
Rated control supply current $I_S$	40 mA
Protective circuit	Surge protection
	Reverse polarity protection

### Insulation characteristics

Rated insulation voltage	500 V
Rated surge voltage	6 kV
Overvoltage category	III
Degree of pollution	2
Insulation characteristics between the control input and control supply voltage, and auxiliary circuit to the main circuit	Safe isolation (IEC 60947-1) at operating voltage ≤ 300 V AC (e. g., 230/400 V AC, 277/480 V AC)
	Basic insulation (IEC 60947-1) at operating voltage 300 V AC ... 500 V AC
Isolation characteristics between the control input and control supply voltage to auxiliary circuit	Safe isolation (IEC 60947-1) in the auxiliary circuit ≤ 300 V AC

### Emergency tripping

Operate threshold	> 45 A
Response time	2 s

## Input data

### Control

Input name	Control input right/left
Rated actuating voltage $U_C$	24 V DC
Triggering voltage range	19.2 V DC ... 30 V DC
Rated actuating current $I_C$	5 mA (Input type 1)
Switching threshold	9.6 V ("0" signal)
	19.2 V ("1" signal)
Typical turn-off time	< 30 ms
Protective circuit	Reverse polarity protection

## Output data

### AC output

Rated operating voltage $U_e$	500 V AC
Operating voltage range	42 V AC ... 550 V AC
Rated operating current $I_e$	9 A (AC-51)
	6.5 A (AC-53a)
Mains frequency	50/60 Hz
Load current range	1.5 A ... 9 A (see to derating)
Trigger characteristic in acc. with IEC 60947-4-2	Class 10A
Cooling time	20 min (for auto reset)
Leakage current	0 mA
Protective circuit	Surge protection

### Acknowledge output

Note	Confirmation: floating change-over contact, signal contact
Contact switching type	1 changeover contact
Switching capacity in accordance with IEC 60947-5-1	3 A (230 V, AC15)
	2 A (24 V (DC13))

## Connection data

### Control circuits

Connection method	Push-in connection
Stripping length	10 mm
Conductor cross-section rigid	0.2 mm <sup>2</sup> ... 2.5 mm <sup>2</sup>
Conductor cross-section flexible	0.2 mm <sup>2</sup> ... 2.5 mm <sup>2</sup>
Conductor cross-section AWG	24 ... 14

### Load circuit

Connection method	Push-in connection
Stripping length	10 mm
Conductor cross-section rigid	0.2 mm <sup>2</sup> ... 2.5 mm <sup>2</sup>
Conductor cross-section flexible	0.2 mm <sup>2</sup> ... 2.5 mm <sup>2</sup>

# ELR H5-I-PT- 24DC/500AC-9 - Hybrid motor starter



2903912

<https://www.phoenixcontact.com/gb/products/2903912>

Conductor cross-section AWG	24 ... 14
-----------------------------	-----------

## Signaling

Status display	LED (yellow)
Operating voltage display	Green LED
Error indication	Red LED

## Dimensions

Width	22.5 mm
Height	107.5 mm
Depth	114 mm

## Material specifications

Flammability rating according to UL 94 (Housing)	V0 (Housing)
--	--------------

## Environmental and real-life conditions

### Ambient conditions

Degree of protection	IP20
Ambient temperature (operation)	-25 °C ... 70 °C (observe derating)
Ambient temperature (storage/transport)	-40 °C ... 80 °C
Altitude	≤ 2000 m

## Approvals

### UL approval

Certificate	NLDX.E228652
-------------	--------------

### UL data

SCCR	100 kA (500 V AC (fuse: 30 A class CC/30 A class J (high fault)))
	5 kA (500 V AC (fuse: 20 A RK5 (standard fault)))
FLA	6.5 A (500 V AC)
Group installation	20 A (class RK5, SCCR 5kA, #24 - 14 AWG max. solid and stranded)
	30 A (class CC or J, SCCR 100kA, #24 - 14 AWG max, solid and stranded)
Category code	NLDX / NRNT

## Standards and regulations

### Standards/regulations

Standards/regulations	IEC 60947-1
	IEC 60947-4-2

## Mounting

Mounting type	DIN rail mounting
Assembly note	alignable, for spacing see derating

# ELR H5-I-PT- 24DC/500AC-9 - Hybrid motor starter



2903912

<https://www.phoenixcontact.com/gb/products/2903912>

Mounting position

vertical (horizontal DIN rail, motor output below)

Drawings

Diagram

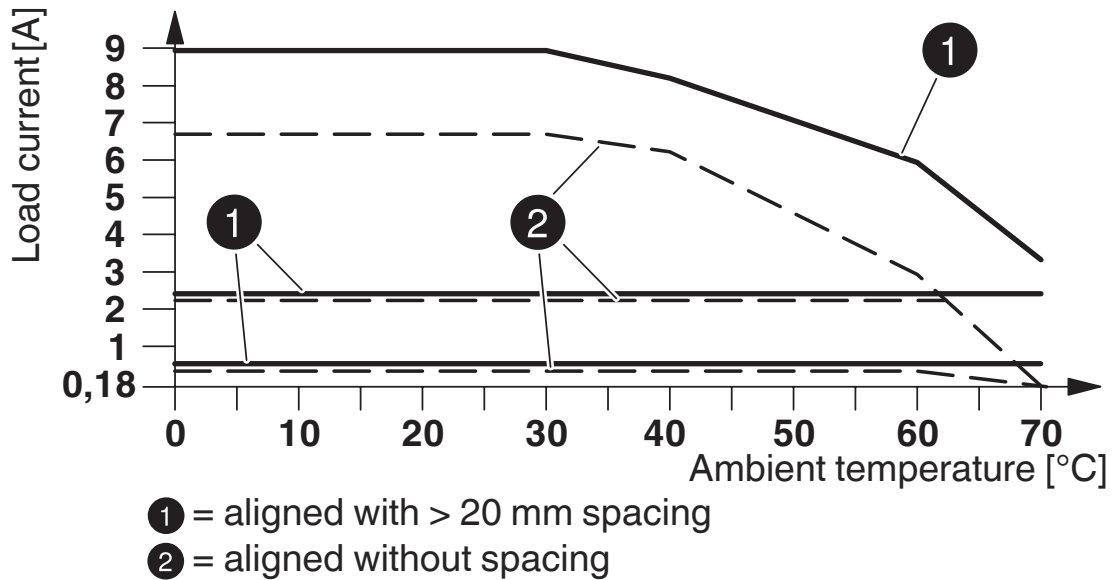

Derating diagram

Block diagram

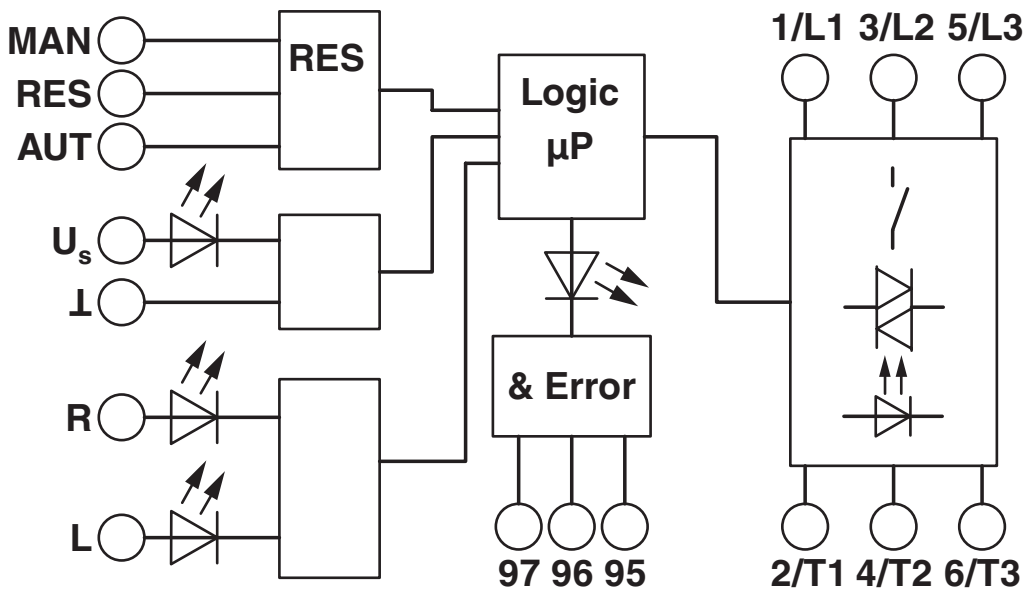

2903912

<https://www.phoenixcontact.com/gb/products/2903912>

## Approvals

To download certificates, visit the product detail page: <https://www.phoenixcontact.com/gb/products/2903912>



**IECEE CB Scheme**  
Approval ID: DE1-55728



**EAC**  
Approval ID: RU\*C-DE.\*08.B.00520\*



**UL Listed**  
Approval ID: FILE E 323771



**CCC**  
Approval ID: 2016010304871315



**cUL Listed**  
Approval ID: FILE E 323771



**cUL Listed**  
Approval ID: E228652



**UL Listed**  
Approval ID: E228652



**CCC**  
Approval ID: 2024010304672817

# ELR H5-I-PT- 24DC/500AC-9 - Hybrid motor starter



2903912

<https://www.phoenixcontact.com/gb/products/2903912>

## Classifications

### ECLASS

ECLASS-13.0	27370905
ECLASS-15.0	27370905

### ETIM

ETIM 10.0	EC001037
-----------	----------

### UNSPSC

UNSPSC 21.0	25173900
-------------	----------

2903912

<https://www.phoenixcontact.com/gb/products/2903912>

## Environmental product compliance

### EU RoHS

Fulfills EU RoHS substance requirements	Yes
Exemption	7(a), 7(c)-I

### China RoHS

Environment friendly use period (EFUP)	EFUP-50
	An article-related China RoHS declaration table can be found in the download area for the respective article under "Manufacturer declaration". For all articles with EFUP-E, no China RoHS declaration table issued and required.

### EU REACH SVHC

REACH candidate substance (CAS No.)	1-Methyl-2-pyrrolidone (NMP)(CAS: 872-50-4)
	Lead(CAS: 7439-92-1)
	2,2',6,6'-tetrabromo-4,4'-isopropylidenediphenol(CAS: 79-94-7)
SCIP	b855dcbe-5a39-4d9c-bb5d-3343e878f8f7

Phoenix Contact 2026 © - all rights reserved  
<https://www.phoenixcontact.com>

PHOENIX CONTACT Ltd  
 Halesfield 13, Telford  
 Shropshire, TF7 4PG  
 01952 681700  
[info@phoenixcontact.co.uk](mailto:info@phoenixcontact.co.uk)