

EMM 3- 24DC/500AC-IFS - Motor management



2297497

<https://www.phoenixcontact.com/gb/products/2297497>

Please be informed that the data shown in this PDF document is generated from our online catalog. Please find the complete data in the user documentation. Our general terms of use for downloads are valid.



Electronic motor management for operation with external current transformer- active power measurement for overload and underload monitoring of motors and systems for optimum protection for all performance classes. Freely parameterizable switching and signaling thresholds.

Your advantages

- Optional connection to INTERFACE system and PROFIBUS-GATEWAY-IFS via TBUS
- Freely parameterizable signaling or switching thresholds
- Digital outputs control external switching elements

Commercial data

Item number	2297497
Packing unit	1 pc
Minimum order quantity	1 pc
Sales key	DK7512
Product key	DK7512
GTIN	4046356175753
Weight per piece (including packing)	263 g
Weight per piece (excluding packing)	263 g
Customs tariff number	85371098
Country of origin	DE

Technical data

Notes

Utilization restriction

EMC note	EMC: class A product, see manufacturer's declaration in the download area
----------	---

Product properties

Product type	Electronic motor manager
Product family	CONTACTRON
Operating mode	100% operating factor

Electrical properties

Number of phases	3
Maximum power dissipation for nominal condition	2.5 W
Test voltage input/output	8 kV

Supply

Rated control circuit supply voltage U_S	24 V DC
Control supply voltage range	19.2 V DC ... 30 V DC
Rated control supply current I_S	25 mA
Switching threshold	9.6 V DC ("0" signal)
	19.2 V DC ("1" signal)

Insulation characteristics

Rated insulation voltage	500 V
Rated surge voltage	6 kV
Overvoltage category	III
Degree of pollution	2
Insulation characteristics between the input and output circuits	Safe isolation (IEC 60947-1)
Insulation characteristics between the thermistor input and output	Basic insulation (IEC 60947-1)

Input data

Digital inputs

Number of inputs	4 (IN1 - IN4)
Rated actuating voltage U_C	24 V DC
Rated actuating current I_C	3.3 mA

Voltage measuring input V1, V2, V3

Input voltage range	42 V AC ... 575 V AC
Typical input current at U_N	< 0.5 mA

Current measuring input L1/T1, L2/T2, L3/T3

Typical input current at U_N	5 A (Secondary external converter)
--------------------------------	------------------------------------

Power measurement

Basic accuracy	typ. 2 %
Power range	4.5 kW (x amplitude transmission factor for current transformer)

Voltage measurement/star voltage

Basic accuracy	typ. 0.75 %
Voltage range	0 V AC ... 350 V AC (Phase-to-neutral voltage)

Current measurement

Basic accuracy	typ. 0.5 %
Current range	140 mA ... 5 A
Measuring via	External push-through current transformers connected upstream

Output data

Output name	Acknowledging contacts O1-O4
Note	The meaning of the acknowledgement outputs can be freely parameterized, see user manual
Number of outputs	4
Nominal output voltage	24 V DC (semiconductor output)
Output voltage range	19.2 V DC ... 30 V DC
Continuous load current	500 mA
Residual voltage	< 200 mV
Protective circuit	Suppressor diode
Surge voltage protection	> 33 V DC

Connection data

Control circuits

Connection method	Screw connection
Stripping length	8 mm
Screw thread	M3
Conductor cross-section rigid	0.2 mm ² ... 2.5 mm ²
Conductor cross-section flexible	0.2 mm ² ... 2.5 mm ²
Conductor cross-section AWG	24 ... 14

Load circuit

Connection method	Screw connection
Stripping length	8 mm
Screw thread	M3
Conductor cross-section rigid	0.2 mm ² ... 2.5 mm ²
Conductor cross-section flexible	0.2 mm ² ... 2.5 mm ²
Conductor cross-section AWG	24 ... 14

Signaling

Status display	LED (yellow)
Operating voltage display	Green LED

EMM 3- 24DC/500AC-IFS - Motor management



2297497

<https://www.phoenixcontact.com/gb/products/2297497>

Error indication	Red LED
Data communication display	green LED

Dimensions

Width	22.5 mm
Height	99 mm
Depth	114.5 mm

Material specifications

Color	gray (RAL 7042)
-------	-----------------

Environmental and real-life conditions

Ambient conditions

Degree of protection	IP20
Ambient temperature (operation)	-25 °C ... 70 °C
Ambient temperature (storage/transport)	-25 °C ... 70 °C

Approvals

ATEX

Identification	⊕ II (2) G [Ex e] [Ex d] [Ex px]
	⊕ II (2) D [Ex t] [Ex p]
Certificate	PTB 10 ATEX 3024

UL, USA/Canada

Certificate	NKCR.E140324
-------------	--------------

Safety Integrity Level (SIL, IEC 61508)

Identification	≤ 1
Note	Safe shutdown

Safety Integrity Level (SIL, IEC 61508)

Identification	1
Note	Motor protection

Category (ISO 13849)

Identification	≤ 1
Note	Safe shutdown

Performance Level

Identification	≤ b
Note	Safe shutdown

Standards and regulations

Standards/regulations

DIN EN 50178

EMM 3- 24DC/500AC-IFS - Motor management



2297497

<https://www.phoenixcontact.com/gb/products/2297497>

Standards/regulations	EN 60947
	EN 60947-4-2

Mounting

Mounting type	DIN rail mounting
Assembly note	in rows with zero spacing
Mounting position	Vertical (horizontal DIN rail)

EMM 3- 24DC/500AC-IFS - Motor management



2297497

<https://www.phoenixcontact.com/gb/products/2297497>

Drawings

Connection diagram

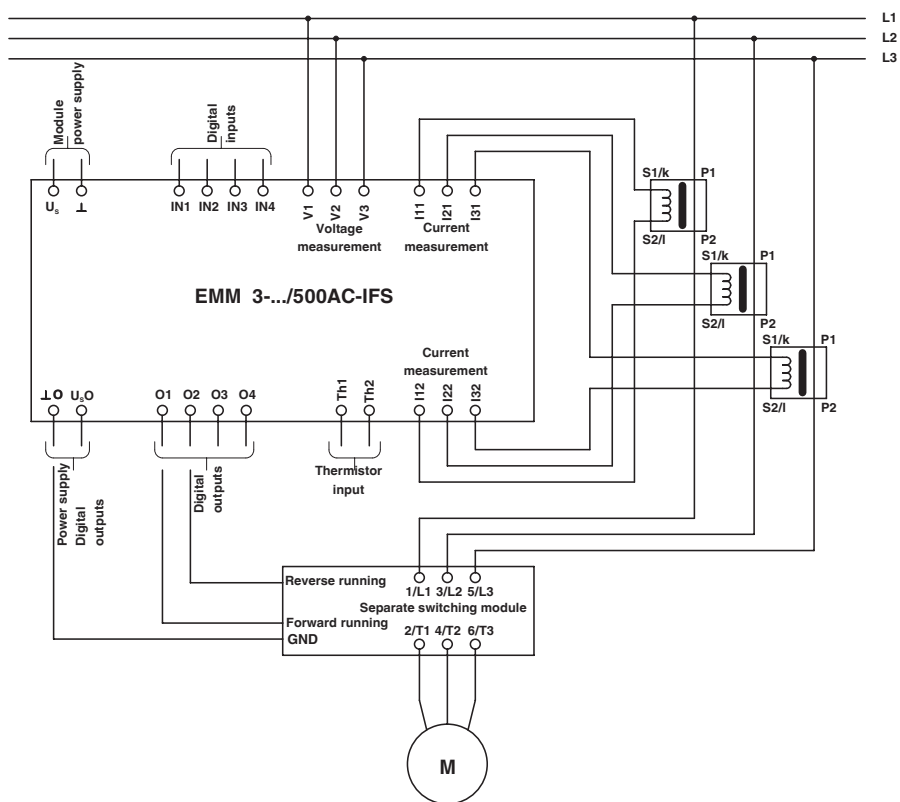

EMM 3- 24DC/500AC-IFS - Motor management



2297497

<https://www.phoenixcontact.com/gb/products/2297497>

Connection diagram

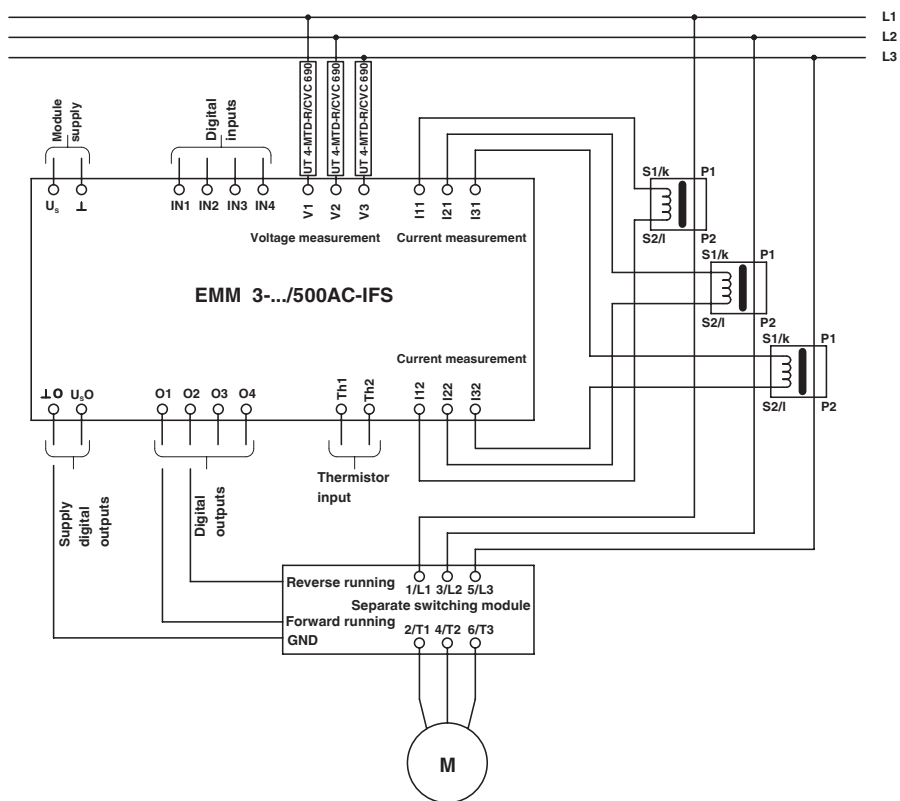

EMM 3-.../500AC-IFS with connected CONTACTRON VOLTAGE CONVERTER

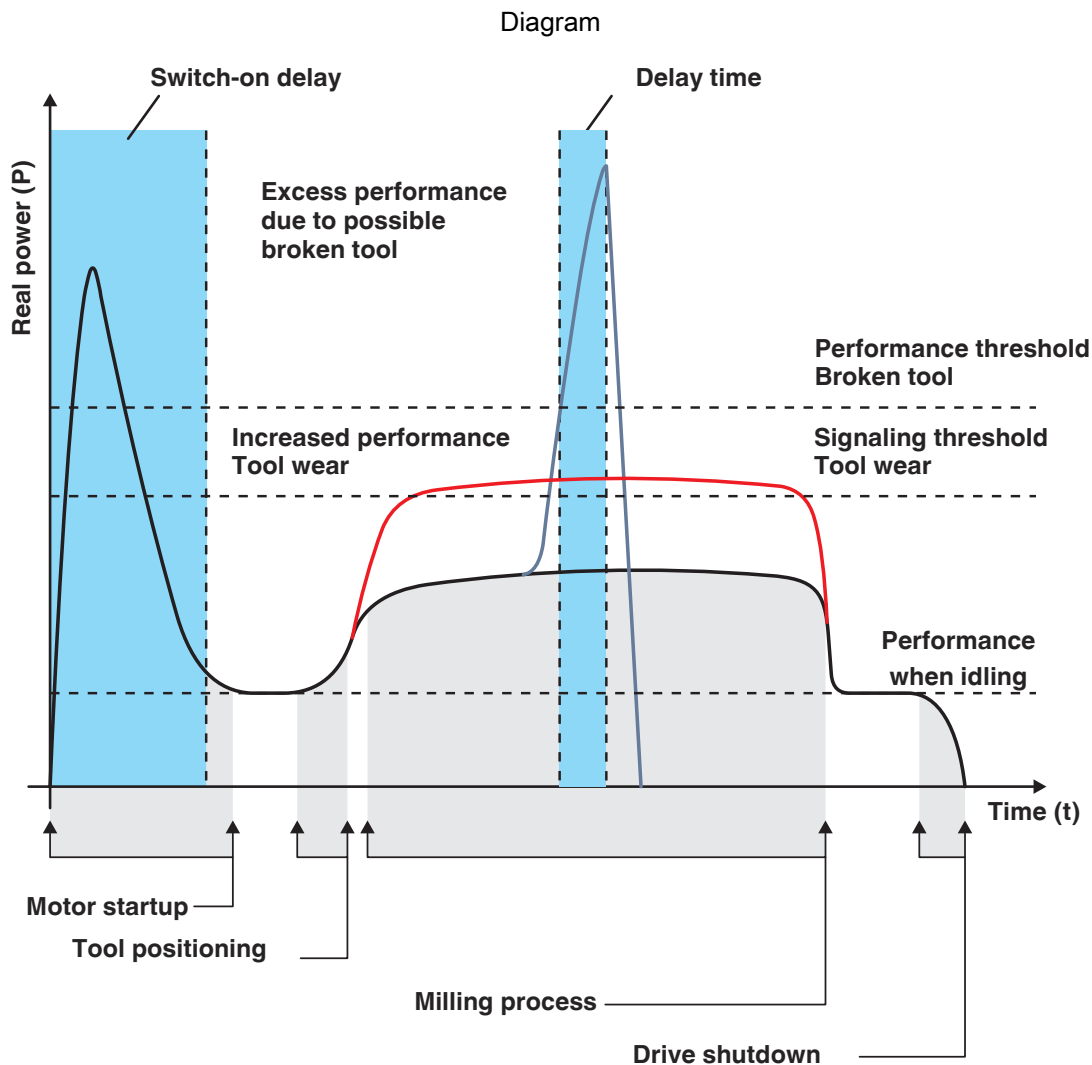

Status monitoring: machine tool for milling

Diagram

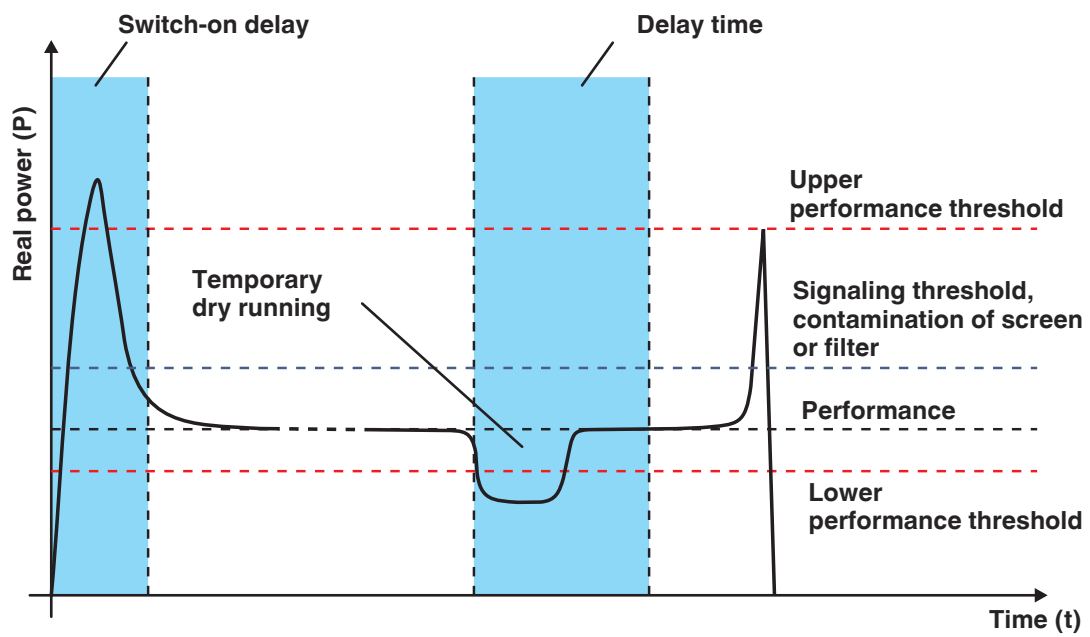

Status monitoring: air bubbles in motor-operated pumps

Diagram

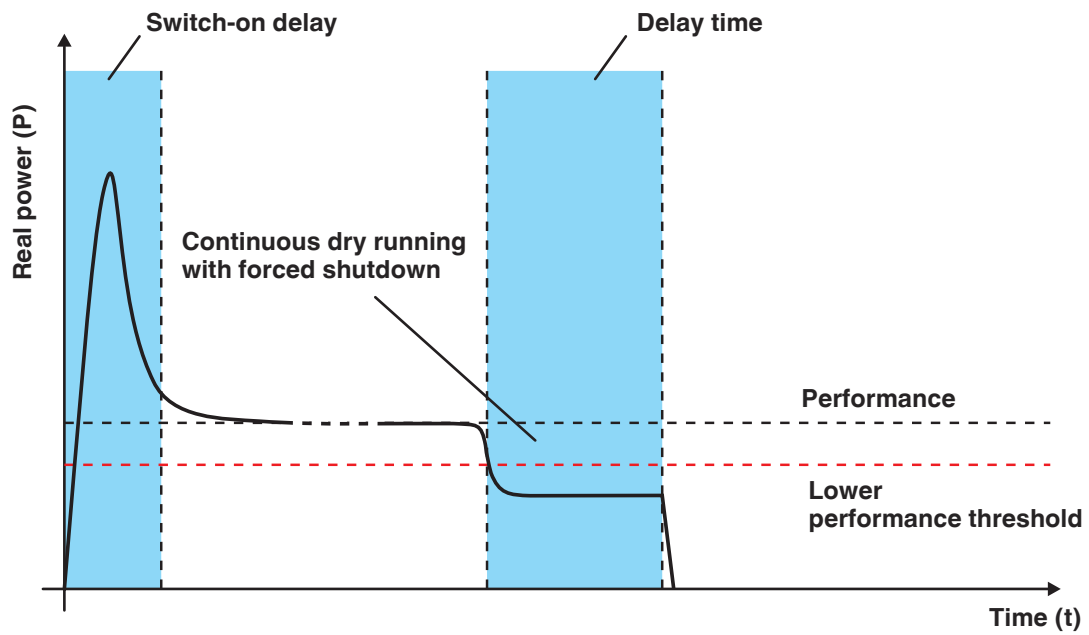

Status monitoring: dry run in motor-operated pumps

2297497

<https://www.phoenixcontact.com/gb/products/2297497>

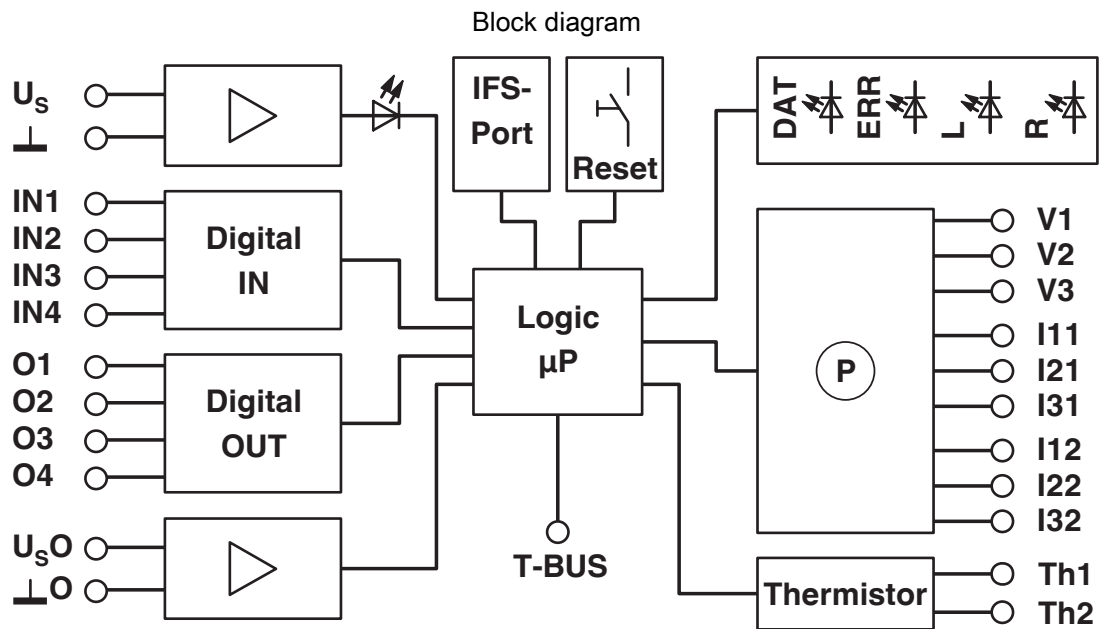

2297497

<https://www.phoenixcontact.com/gb/products/2297497>

Classifications

ECLASS

ECLASS-13.0

27370804

ETIM

ETIM 9.0

EC002572

UNSPSC

UNSPSC 21.0

39121100

2297497

<https://www.phoenixcontact.com/gb/products/2297497>

Environmental product compliance

EU RoHS

Fulfills EU RoHS substance requirements	Yes
Exemption	7(a), 7(c)-I, 7(c)-II

China RoHS

Environment friendly use period (EFUP)	EFUP-50
	An article-related China RoHS declaration table can be found in the download area for the respective article under "Manufacturer declaration". For all articles with EFUP-E, no China RoHS declaration table issued and required.

EU REACH SVHC

REACH candidate substance (CAS No.)	Lead(CAS: 7439-92-1)
SCIP	141e0f24-6c49-48b6-a9f1-f1b2bd215171

Phoenix Contact 2026 © - all rights reserved

<https://www.phoenixcontact.com>

PHOENIX CONTACT Ltd
Halesfield 13, Telford
Shropshire, TF7 4PG
01952 681700
info@phoenixcontact.co.uk