

# VAL-SEC-T2-2+F-220DC-FM - Type 2 surge arrester



1033789

<https://www.phoenixcontact.com/gb/products/1033789>

Please be informed that the data shown in this PDF document is generated from our online catalog. Please find the complete data in the user documentation. Our general terms of use for downloads are valid.



Pluggable surge protective device free of leakage current for 2-pos. isolated and grounded DC voltage systems with linear operating characteristic up to 220 V DC, for DIN rail mounting, 3-pos. base element with remote indication contact, three pluggable temperature-monitored protective elements, status message on each plug.

## Your advantages

- Surge protection family for universal use with optimum energy coordination from the lightning current arrester to the device protection
- Easy to maintain due to consistently pluggable protection modules
- Excellent level of information provided by mechanical/visual status indicator and remote indication contact
- More space in the control cabinet due to the narrow overall width of just 12 mm per position
- Free of leakage current so there is no influence on insulation monitoring

## Commercial data

Item number	1033789
Packing unit	1 pc
Minimum order quantity	10 pc
Note	Made to order (non-returnable)
Sales key	CL1353
Product key	CL1353
GTIN	4055626539720
Weight per piece (including packing)	310.7 g
Weight per piece (excluding packing)	287.43 g
Customs tariff number	85363090
Country of origin	DE

# VAL-SEC-T2-2+F-220DC-FM - Type 2 surge arrester



1033789

<https://www.phoenixcontact.com/gb/products/1033789>

## Technical data

### Product properties

Product type	Surge arrester
Product family	SEC Family
IEC test classification	II T2
EN type	T2
IEC power supply system	DC
Type	DIN rail module, two-section, divisible
Number of positions	2
Surge protection fault message	Optical, remote indicator contact
Number of ports	One

### Insulation characteristics

Overvoltage category	III
Pollution degree	2

### Electrical properties

Nominal voltage $U_N$	200 V DC ... 220 V DC
-----------------------	-----------------------

### Indicator/remote signaling

Connection name	Remote fault indicator contact
Switching function	Changeover contact
Operating voltage	5 V AC ... 250 V AC (Altitude $\leq$ 2000 m (amsl)) 5 V AC ... 150 V AC (Altitude $>$ 2000 m (amsl)) 125 V DC (200 mA DC)
Operating current	5 mA AC ... 1 A AC 1 A DC (30 V DC)

### Connection data

Connection method	Screw connection
Screw thread	M5
Tightening torque	4.5 Nm
Stripping length	16 mm
Conductor cross-section flexible	2.5 mm <sup>2</sup> ... 16 mm <sup>2</sup>
Conductor cross-section rigid	2.5 mm <sup>2</sup> ... 25 mm <sup>2</sup>
Conductor cross-section AWG	12 ... 4
Connection method	Fork-type cable lug
Conductor cross-section flexible	1.5 mm <sup>2</sup> ... 6 mm <sup>2</sup>

### Remote fault indicator contact

Connection method	Plug-in/screw connection via COMBICON
Screw thread	M2
Tightening torque	0.25 Nm

# VAL-SEC-T2-2+F-220DC-FM - Type 2 surge arrester



1033789

<https://www.phoenixcontact.com/gb/products/1033789>

Stripping length	7 mm
Conductor cross-section flexible	0.14 mm <sup>2</sup> ... 1.5 mm <sup>2</sup>
Conductor cross-section rigid	0.14 mm <sup>2</sup> ... 1.5 mm <sup>2</sup>
Conductor cross-section AWG	28 ... 16

## Dimensions

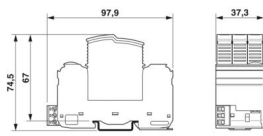
Dimensional drawing	
Width	37.3 mm
Height	97.9 mm
Depth	74.5 mm (incl. DIN rail 7.5 mm)
Horizontal pitch	2 Div.

## Material specifications

Color (Male connector)	light gray (RAL 7035)
Color (Base element)	gray (RAL 7042)
Flammability rating according to UL 94	V-0
CTI value of material	600
Insulating material	PA6.6-FR 20% GF PBT-FR
Material group	I
Housing material	PA 6.6-FR 20 % GF PBT-FR

## Protective circuit

Mode of protection	(DC+) - (DC-) (DC+/DC-) - PE
Direction of action	(DC+/DC-) - PE
Nominal voltage $U_N$	200 V DC ... 220 V DC
Maximum continuous operating voltage $U_C$	250 V DC
Rated load current $I_L$	40 A (Biconnect M4 fork-type cable lug 6 mm <sup>2</sup> ) 63 A (TWIN ferrule 2 x 10 mm <sup>2</sup> )
Protective conductor current $I_{PE}$	≤ 5 μA
Nominal discharge current $I_n$ (8/20) μs	20 kA
Maximum discharge current $I_{max}$ (8/20) μs	40 kA
Total discharge current $I_{Total}$ (8/20) μs	40 kA
Short-circuit current rating $I_{SCCR}$	0.2 kA (without backup fuse) 6 kA (for 20 A gG/B backup fuse)
Voltage protection level $U_p$ (DC+) - (DC-)	≤ 3 kV
Voltage protection level $U_p$ (DC+/DC-) - PE	≤ 1.9 kV

# VAL-SEC-T2-2+F-220DC-FM - Type 2 surge arrester



1033789

<https://www.phoenixcontact.com/gb/products/1033789>

Front-of-wave sparkover voltage at 6 kV (1.2/50) $\mu$ s (DC+/DC-) - PE	$\leq 1.9$ kV
TOV behavior at $U_T$	320 V DC (5 s / withstand mode)
Response time $t_A$ (DC+) - (DC-)	25 ns
Response time $t_A$ (DC+/DC-) - PE	100 ns
Max. backup fuse with V-type through wiring	20 A (gG / B at $I_{SCCR} > 200$ A)
Max. backup fuse with branch wiring	20 A (gG / B at $I_{SCCR} > 200$ A)

## Additional technical data

Maximum continuous operating voltage $U_C$	264 V AC (for operation in safety lighting systems)
Maximum continuous operating voltage $U_{CPV}$	250 V DC
Short-circuit current rating $I_{SCPV}$	2000 A
Continuous operating current $I_{CPV}$	10 $\mu$ A

## Environmental and real-life conditions

### Ambient conditions

Degree of protection	IP20
Ambient temperature (operation)	-40 °C ... 80 °C
Ambient temperature (storage/transport)	-40 °C ... 80 °C
Altitude	$\leq 5000$ m (amsl)
Permissible humidity (operation)	5 % ... 95 %
Shock (operation)	30g (Half-sine / 11 ms / $3x \pm X, \pm Y, \pm Z$ )
Vibration (operation)	5g (10 ... 500 Hz / 2.5 h / X, Y, Z)

## Standards and regulations

Standards/specifications	IEC 61643-11
Note	2011

### EN 61643-11

Standards/specifications	EN 61643-11
Note	2012

## Mounting

Mounting type	DIN rail: 35 mm
---------------	-----------------

# VAL-SEC-T2-2+F-220DC-FM - Type 2 surge arrester

1033789

<https://www.phoenixcontact.com/gb/products/1033789>

## Drawings

Dimensional drawing

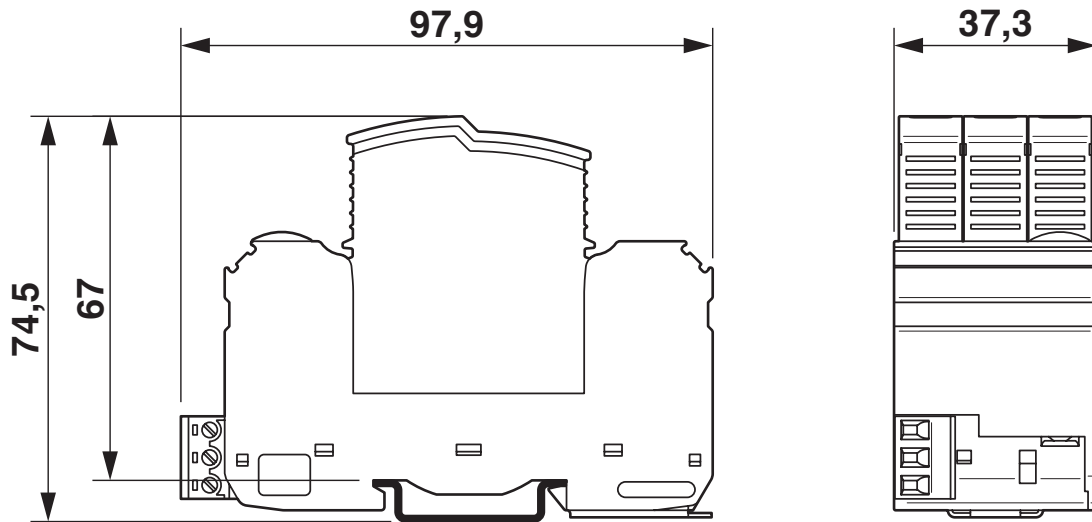

Circuit diagram

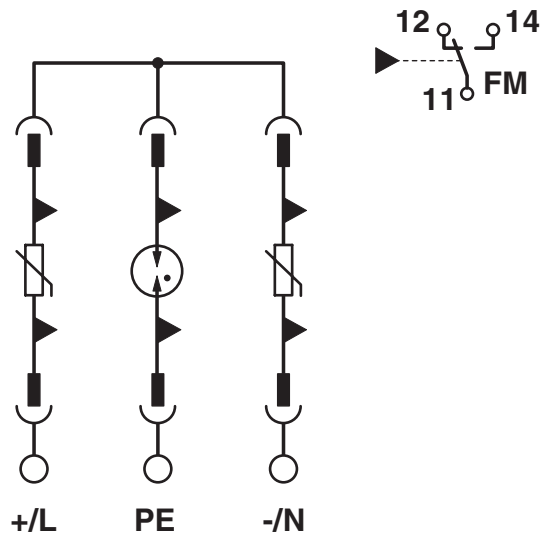

# VAL-SEC-T2-2+F-220DC-FM - Type 2 surge arrester



1033789

<https://www.phoenixcontact.com/gb/products/1033789>

## Approvals

🔗 To download certificates, visit the product detail page: <https://www.phoenixcontact.com/gb/products/1033789>

### **UAE-RoHS**

Approval ID: 23-10-88707

# VAL-SEC-T2-2+F-220DC-FM - Type 2 surge arrester



1033789

<https://www.phoenixcontact.com/gb/products/1033789>

## Classifications

### ECLASS

ECLASS-13.0	27171302
ECLASS-15.0	27171302

### ETIM

ETIM 10.0	EC000941
-----------	----------

### UNSPSC

UNSPSC 21.0	39121600
-------------	----------

# VAL-SEC-T2-2+F-220DC-FM - Type 2 surge arrester



1033789

<https://www.phoenixcontact.com/gb/products/1033789>

## Environmental product compliance

### EU RoHS

Fulfills EU RoHS substance requirements	Yes, No exemptions
---	--------------------

### China RoHS

Environment friendly use period (EFUP)	EFUP-E
	No hazardous substances above the limits

### EU REACH SVHC

REACH candidate substance (CAS No.)	No substance above 0.1 wt%
-------------------------------------	----------------------------

Phoenix Contact 2026 © - all rights reserved  
<https://www.phoenixcontact.com>

PHOENIX CONTACT Ltd  
Halesfield 13, Telford  
Shropshire, TF7 4PG  
01952 681700  
[info@phoenixcontact.co.uk](mailto:info@phoenixcontact.co.uk)