

ZFKDS 1,5-W-5,08 - PCB terminal block

1706714

<https://www.phoenixcontact.com/us/products/1706714>

Please be informed that the data shown in this PDF document is generated from our online catalog. Please find the complete data in the user documentation. Our general terms of use for downloads are valid.

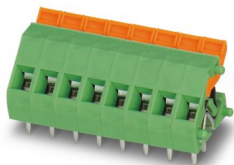

The figure shows an 8-position version, with and without actuation rocker

Printed circuit board terminal, nominal current: 16 A, rated voltage (III/2): 400 V, nominal cross section: 1.5 mm², number of potentials: 1, number of rows: 1, number of positions per row: 1, product range: ZFKDS(A) 1,5-W, pitch: 5.08 mm, connection method: Spring-cage connection, mounting: Wave soldering, conductor/PCB connection direction: 45 °, color: green, Pin layout: Linear pinning, Solder pin [P]: 3.5 mm, number of solder pins per potential: 2, type of packaging: packed in cardboard. Single module for the custom grouping of different numbers of positions. An end terminal block is also needed to terminate the block (see accessories). Blocked items with different numbers of positions are also available.

Your advantages

- Defined contact force ensures that contact remains stable over the long term
- Can be operated without tools by means of color-coded actuating lever
- Angled connection enables multi-row arrangement on the PCB
- The latching on the side enables various numbers of positions to be combined
- Two solder pins reduce the mechanical strain on the soldering spots

Commercial data

Item number	1706714
Packing unit	250 pc
Minimum order quantity	250 pc
Sales key	AA12
Product key	AALMBF
GTIN	4017918144746
Weight per piece (including packing)	1.258 g
Weight per piece (excluding packing)	1.172 g
Customs tariff number	85369010
Country of origin	IN

1706714

<https://www.phoenixcontact.com/us/products/1706714>

Technical data

Product properties

Product type	Printed circuit board terminal
Product family	ZFKDS(A) 1,5-W
Product line	COMBICON Terminals S
Type	PC terminal block can be aligned
Number of positions	1
Pitch	5.08 mm
Number of connections	1
Number of rows	1
Number of potentials	1
Pin layout	Linear pinning
Solder pins per potential	2

Electrical properties

Properties

Nominal current I_N	16 A
Nominal voltage U_N	400 V
Rated voltage (III/3)	250 V
Rated surge voltage (III/3)	4 kV
Rated voltage (III/2)	400 V
Rated surge voltage (III/2)	4 kV
Rated voltage (II/2)	630 V
Rated surge voltage (II/2)	4 kV

Connection data

Connection technology

Nominal cross section	1.5 mm ²
-----------------------	---------------------

Conductor connection

Connection method	Spring-cage connection
Conductor cross-section rigid	0.2 mm ² ... 2.5 mm ²
Conductor cross-section flexible	0.2 mm ² ... 1.5 mm ²
Conductor cross-section AWG	24 ... 14
Conductor cross-section, flexible, with ferrule, without plastic sleeve	0.25 mm ² ... 1.5 mm ²
Conductor cross-section, flexible, with ferrule, with plastic sleeve	0.25 mm ² ... 1.5 mm ²
Stripping length	7.5 mm

Mounting

Mounting type	Wave soldering
Pin layout	Linear pinning

ZFKDS 1,5-W-5,08 - PCB terminal block

1706714

<https://www.phoenixcontact.com/us/products/1706714>

Material specifications

Material data - contact

Note	WEEE/RoHS-compliant, free of whiskers according to IEC 60068-2-82/JEDEC JESD 201
Contact material	Cu alloy
Surface characteristics	hot-dip tin-plated
Metal surface terminal point (top layer)	Tin (10 µm - 16 µm Sn)
Metal surface soldering area (top layer)	Tin (10 µm - 16 µm Sn)

Material data - housing

Color (Housing)	green (6021)
Insulating material	PA
Insulating material group	I
CTI according to IEC 60112	600
Flammability rating according to UL 94	V0
Glow wire flammability index GWFI according to EN 60695-2-12	850
Glow wire ignition temperature GWIT according to EN 60695-2-13	775
Temperature for the ball pressure test according to EN 60695-10-2	125 °C

Material data – actuating element

Color (Actuating element)	green (6021)
---------------------------	--------------

Dimensions

Dimensional drawing	
Pitch	5.08 mm
Width [w]	7.62 mm
Height [h]	17.7 mm
Length [l]	16.9 mm
Installed height	14.2 mm
Solder pin length [P]	3.5 mm

PCB design

Hole diameter	1.3 mm
---------------	--------

Electrical tests

Air clearances and creepage distances |

Insulating material group	I
Rated insulation voltage (III/3)	250 V

ZFKDS 1,5-W-5,08 - PCB terminal block



1706714

<https://www.phoenixcontact.com/us/products/1706714>

Rated surge voltage (III/3)	4 kV
Rated insulation voltage (III/2)	400 V
Rated surge voltage (III/2)	4 kV
Rated insulation voltage (II/2)	630 V
Rated surge voltage (II/2)	4 kV

Environmental and real-life conditions

Ambient conditions

Ambient temperature (storage/transport)	-40 °C ... 70 °C
Relative humidity (storage/transport)	30 % ... 70 %
Ambient temperature (assembly)	-5 °C ... 100 °C
Ambient temperature (operation)	-40 °C ... 100 °C (Depending on the current carrying capacity/derating curve)

Packaging specifications

Type of packaging	packed in cardboard
Note	The item is preassembled at the factory into 10-pos. blocks. For smaller numbers of positions, the washers must be removed by the customer

ZFKDS 1,5-W-5,08 - PCB terminal block

1706714

<https://www.phoenixcontact.com/us/products/1706714>

Drawings

Dimensional drawing

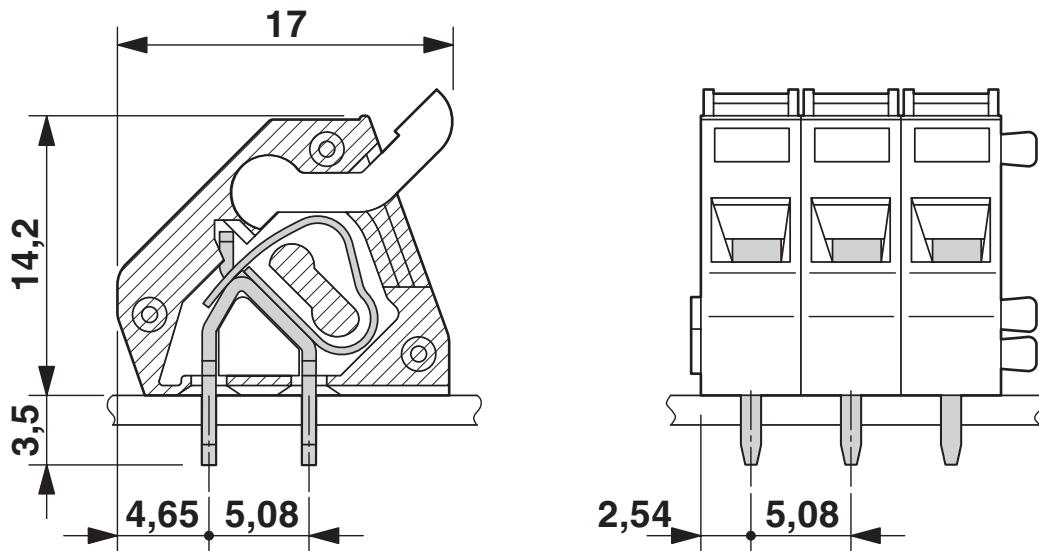

Drilling plan/solder pad geometry

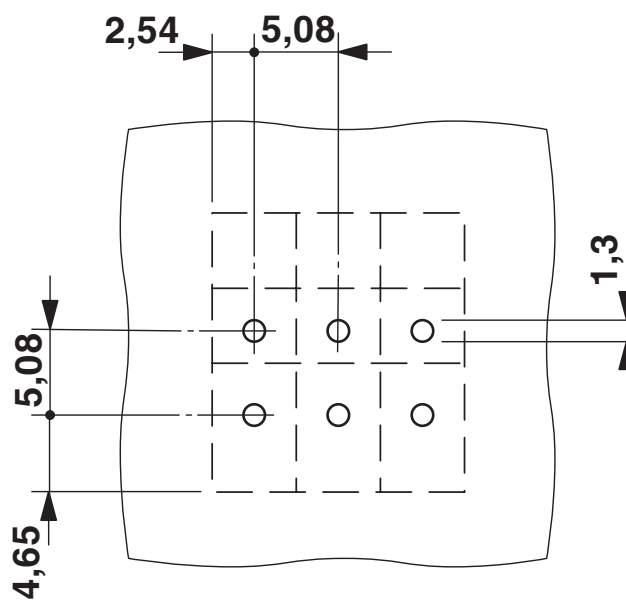

ZFKDS 1,5-W-5,08 - PCB terminal block





1706714

<https://www.phoenixcontact.com/us/products/1706714>

Approvals

To download certificates, visit the product detail page: <https://www.phoenixcontact.com/us/products/1706714>

 CSA Approval ID: 13631				
	Nominal voltage U_N	Nominal current I_N	Cross section AWG	Cross section mm^2
B	300 V	10 A	28 - 12	-
D	300 V	10 A	28 - 12	-

 KEMA-KEUR Approval ID: 2160724.01				
	Nominal voltage U_N	Nominal current I_N	Cross section AWG	Cross section mm^2
keine				
Only flexible conductors	250 V	-	-	0.2 - 1.5
Only rigid conductors	250 V	-	-	0.2 - 2.5

ZFKDS 1,5-W-5,08 - PCB terminal block



1706714

<https://www.phoenixcontact.com/us/products/1706714>

Classifications

ECLASS

ECLASS-13.0	27460101
ECLASS-15.0	27460101

ETIM

ETIM 10.0	EC002643
-----------	----------

UNSPSC

UNSPSC 21.0	39121400
-------------	----------

ZFKDS 1,5-W-5,08 - PCB terminal block



1706714

<https://www.phoenixcontact.com/us/products/1706714>

Environmental product compliance

EU RoHS

Fulfills EU RoHS substance requirements	Yes, No exemptions
---	--------------------

China RoHS

Environment friendly use period (EFUP)	EFUP-E
	No hazardous substances above the limits

EU REACH SVHC

REACH candidate substance (CAS No.)	No substance above 0.1 wt%
-------------------------------------	----------------------------

Phoenix Contact 2026 © - all rights reserved
<https://www.phoenixcontact.com>

Phoenix Contact USA
586 Fulling Mill Road
Middletown, PA 17057, United States
(+717) 944-1300
info@phoenixcon.com