

Single-Phase Power Supply Unit, Primary Switched for Universal Use QUINT-PS-100-240AC/24DC/40

QUINT POWER provides:

- **Preventive function monitoring** through professional signaling
- **Global use** due to a wide-range input
- **A high level of operational safety** even in complex global networks
- **Reliable startup of heavy loads** due to POWER BOOST

The reliability of a power supply unit determines the availability of individual components in a system and whether complex systems can function safely.

The globalization of markets increases the demands placed on the power supply unit. A wide-range input and a high level of availability are required.

These requirements are met by Generation 2 QUINT POWER.



1. Short Description

The QUINT POWER product range offers universal DC power supplies from 60 - 960 W. Depending on the type, regulated and adjustable output voltages of 12 V DC, 24 V DC or 48 V DC are available for output currents of 2.5 A, 5 A, 10 A, 20 A, 30 A, and 40 A.

These devices, which are designed as primary switched-mode regulators, operate with a high level of efficiency so that heat loss is kept to a minimum.

The high level of operational safety is also ensured in complex global networks. QUINT POWER also operates in applications where static voltage dips, transient power supply failures or phase failure are common.

Powerful capacitors ensure mains buffering of more than 20 ms at full load. All 3-phase QUINT POWER units provide the complete output power even in the event of a continuous phase failure.

Reliable startup of heavy loads is ensured by a power reserve of up to 50% – the POWER BOOST.

Preventive function monitoring diagnoses an impermissible operating state and minimizes downtimes in your system. An active transistor output and a floating relay contact are provided for remote monitoring of this state.

This signal not only provides information on the device function, but also indicates a system overload at an early stage.

2. Area of Application

QUINT POWER can be used globally due to the consistent provision of a wide-range input.



In this way, your entire system can be tested at any production location in the world and can be delivered to any location in the world without faulty switching of the input voltage. This reduces storage costs and logistical effort.

An international approval package including CB Scheme, UL 60950 for IT equipment, and UL 508 for industrial control equipment enables the device to be used globally.

Safe operation in adverse conditions is emphasized by the approval of all QUINT POWER units with 24 V output voltage by Germanischer Lloyd.

Single-Phase Primary-Switched Power Supply Unit for Universal Use – QUINT 24 V DC/40 A

General Data

Insulation voltage:	Input/output Input/PE Output/PE	3 kV AC (type test)/2 kV AC (routine test) 3 kV AC (type test)/1.5 kV AC (routine test) 500 V DC (routine test) EN 60 204 (Surge Voltage Category III) EN 61 558-2-17 EN 60950/VDE 0805, UL/C-UL Recognized UL 60 950  UL/C-UL Listed UL 508  LISTED
Electrical equipment of machines Safety transformers for switched-mode power supply units Electrical safety (of IT equipment) Industrial control equipment Equipping high voltage installations with electronic equipment Safety extra-low voltage		EN 50 178 (VDE 0160) PELV (EN 60 204) SELV (EN 60 950) VDE 0100-410 DIN 57100-410
Safe isolation Protection against electric shock Protection against electric shock, basic requirements for safe isolation in electrical equipment Limitation of harmonic line currents		DIN VDE 0106-101 According to EN 61000-3-2
Mounting position Degree of protection Class of protection MTBF Housing version Dimensions (W x H x D) + DIN rail		On horizontal NS 35 DIN rail according to EN 60715 IP20 I, with PE connection > 500,000 h according to IEC 1709 (SN 29 500) AluNox (AlMg1), closed Default upon delivery: Rotated 90°: (240 x 130 x 125) mm (122 x 130 x 243) mm
Weight		2.5 kg, approximately

Climatic Data

Ambient temperature	Operation Storage	-25°C to +70°C (> +60°C derating) -40°C to +85°C
Humidity		Up to 95% at +25°C, no condensation
Vibration	According to IEC 68-2-6	< 15 Hz, amplitude ±2.5 mm/15 Hz - 150 Hz, 2.3g, 90 minutes
Shock	According to IEC 68-2-27	30g in all space directions
Pollution degree		2 (according to EN 50 178)
Climatic category		3K3 (according to EN 60 721)



Conformance With EMC Directive 89/336/EEC and the Low Voltage Directive 73/23/EEC

EMC (Electromagnetic Compatibility)

Noise Immunity According to EN 61000-6-2:

Electrostatic discharge (ESD)	EN 61000-4-2 ³⁾	Housing Contact discharge: Air discharge:
Electromagnetic HF field	EN 61000-4-3 ²⁾	Housing Frequency: Field strength:
Fast transients (burst)	EN 61000-4-4 ³⁾	Input: Output: Signal:
Surge current loads (surge)	EN 61000-4-5 ³⁾	Input: Output: Signal:
Conducted interference	EN 61000-4-6 ²⁾	I/O/S: Frequency: U ₀ :
Voltage dips	EN 61000-4-11 ³⁾	Input:

Noise Emission According to EN 61000-6-3:

Radio interference	EN 55011
Radio interference	EN 55011

EN 55011 corresponds to CISPR11/EN 55022 corresponds to CISPR22

EN 61000 corresponds to IEC 1000

- ²⁾ Criterion A: Normal operating characteristics within the specified limits.
³⁾ Criterion B: Temporary adverse effects on the operating characteristics, which the device corrects automatically.

Requirements

EN 61 000-6-2 QUINT-PS-100-240AC/24DC/40

4 kV		Level 4
8 kV		8 kV
8 kV		15 kV
80 - 1000 MHz		Level 3
10 V/m		80 - 1000 MHz/1.4 - 2.0 GHz
2 kV	asymmetrical ⁵⁾	4 kV (Level 4)
2 kV	asymmetrical ⁵⁾	2 kV (Level 3)
1 kV	asymmetrical ⁵⁾	1 kV (Level 2)
2 kV	asymmetrical ⁵⁾	4 kV (Inst. Class 4)
1 kV	symmetrical ⁴⁾	2 kV (Inst. Class 4)
0.5 kV	asymmetrical ⁵⁾	0.5 kV (Level 1)
0.5 kV	symmetrical ⁴⁾	0.5 kV (Level 1)
1 kV	asymmetrical ⁵⁾	1 kV (Level 2)
	asymmetrical ⁵⁾	Level 3
0.15 - 80 MHz		0.15 - 80 MHz
10 V		10 V
30% reduction of the input voltage for 0.5 periods		See Input Data: Mains buffering > 20 ms

Class A⁶⁾ EN 55011 (EN 55022) Class B⁷⁾

Class A⁶⁾ EN 55011 (EN 55022) Class B⁷⁾

- ⁴⁾ Symmetrical: Cable to cable
⁵⁾ Asymmetrical: Cable to ground

- ⁶⁾ Class A: Industrial applications
⁷⁾ Class B: Industrial and domestic applications

4. Device View, Connections, and Control Elements

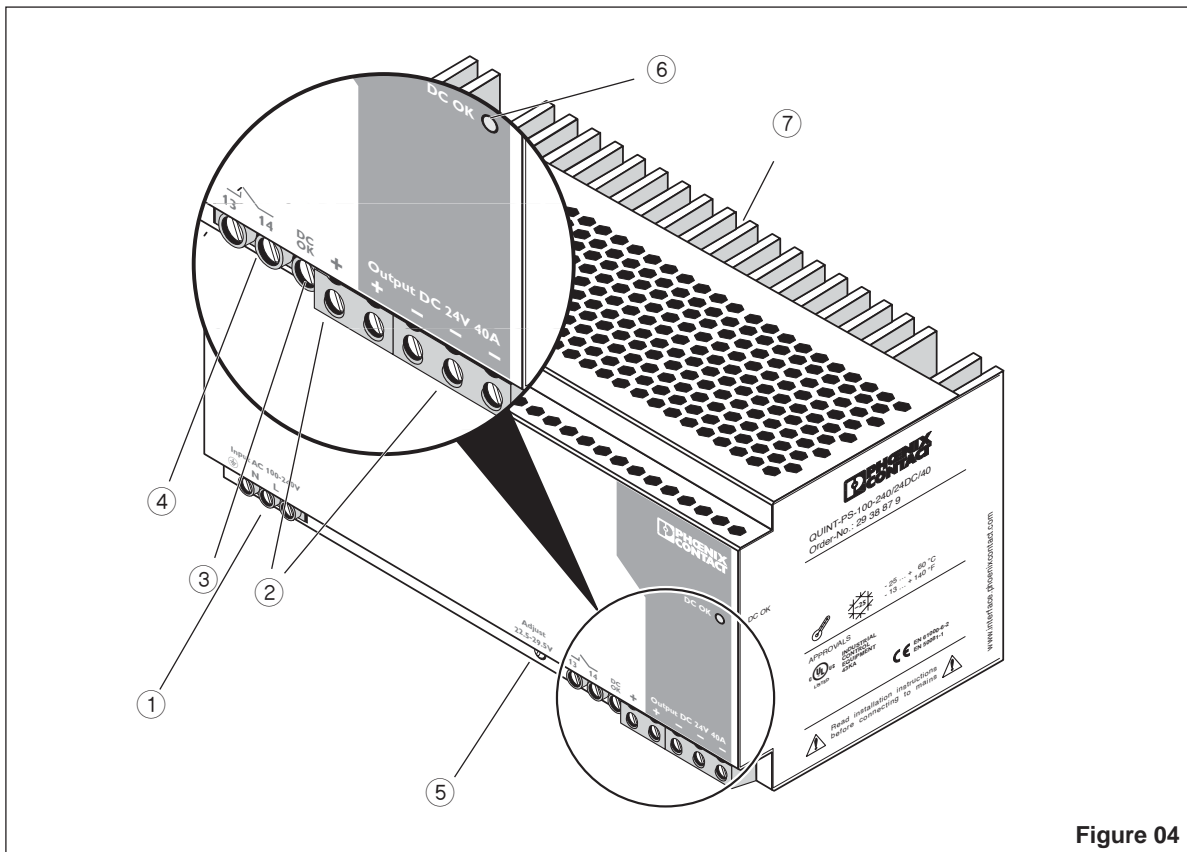

Figure 04

- ① **AC input:**
85 - 264 V AC input voltage
Frequency 45 - 65 Hz
(0.2 mm² to 6 mm² solid)
(0.2 mm² to 4 mm² stranded)
(25 - 10 AWG)
Internal fuse 20 AT
Recommended fuse
16 A or 25 A LS/characteristic B
- ② **DC output:**
24 V DC output voltage (default),
can be set from 22.5 - 28.5 V DC using
a potentiometer ⑤ (0.5 mm² to 16 mm² solid)
(0.5 mm² to 10 mm² stranded) (20 - 6 AWG)
The device is idling-proof and short-circuit-proof.
- ③ **DC OK output active**
- ④ **DC OK output electrically isolated**
- ⑤ **Potentiometer (covered) 22.5 - 28.5 V DC**
- ⑥ **DC OK LED**
- ⑦ **Universal DIN rail adapter UTA 107**

QUINT POWER is a built-in device. **Installation and startup** must only be carried out by qualified personnel. The relevant country-specific regulations (e.g., VDE, DIN) must also be observed.

Before startup it is particularly important to ensure that:

- The mains has been connected correctly and protection is provided against electric shock.
- The device can be switched off outside the power supply according to EN 60950 regulations (e.g., by the mains protection on the primary side).
- The protective conductor is connected.
- All supply lines have sufficient fuse protection and are the correct size.
- All output cables are the correct size for the maximum device output current or have separate fuse protection.
- Sufficient convection is ensured.

The housing temperature can reach high values depending on the ambient operating temperature and the load of the device.

The device contains dangerous live components and high levels of stored energy.

5. Safety Notes and Warning Instructions

To ensure that the device can be operated safely and all functions can be used, please read these instructions carefully.

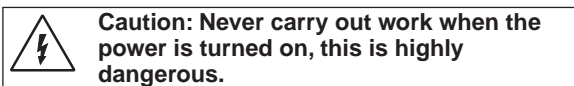

6. Installation

6.1. Mounting

The power supply unit can be snapped onto all DIN rails according to EN 60715 and should be mounted horizontally (input terminal blocks facing downwards).

Installation Dimensions



To ensure sufficient convection, we recommend the following minimum spacing be used between modules:

8.0 cm for vertical installation
0.0 cm for horizontal installation

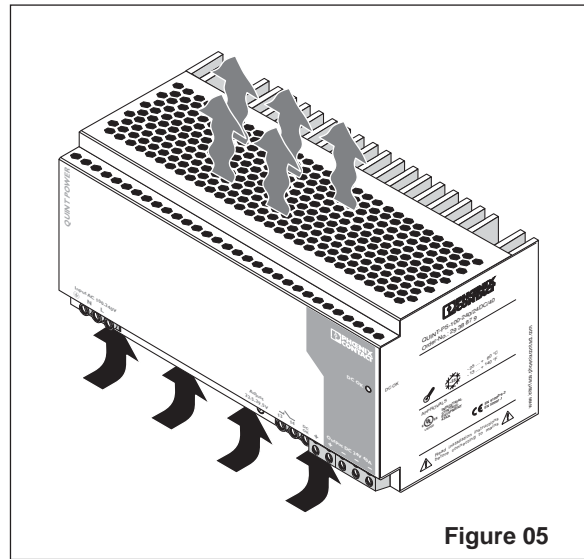

Figure 05

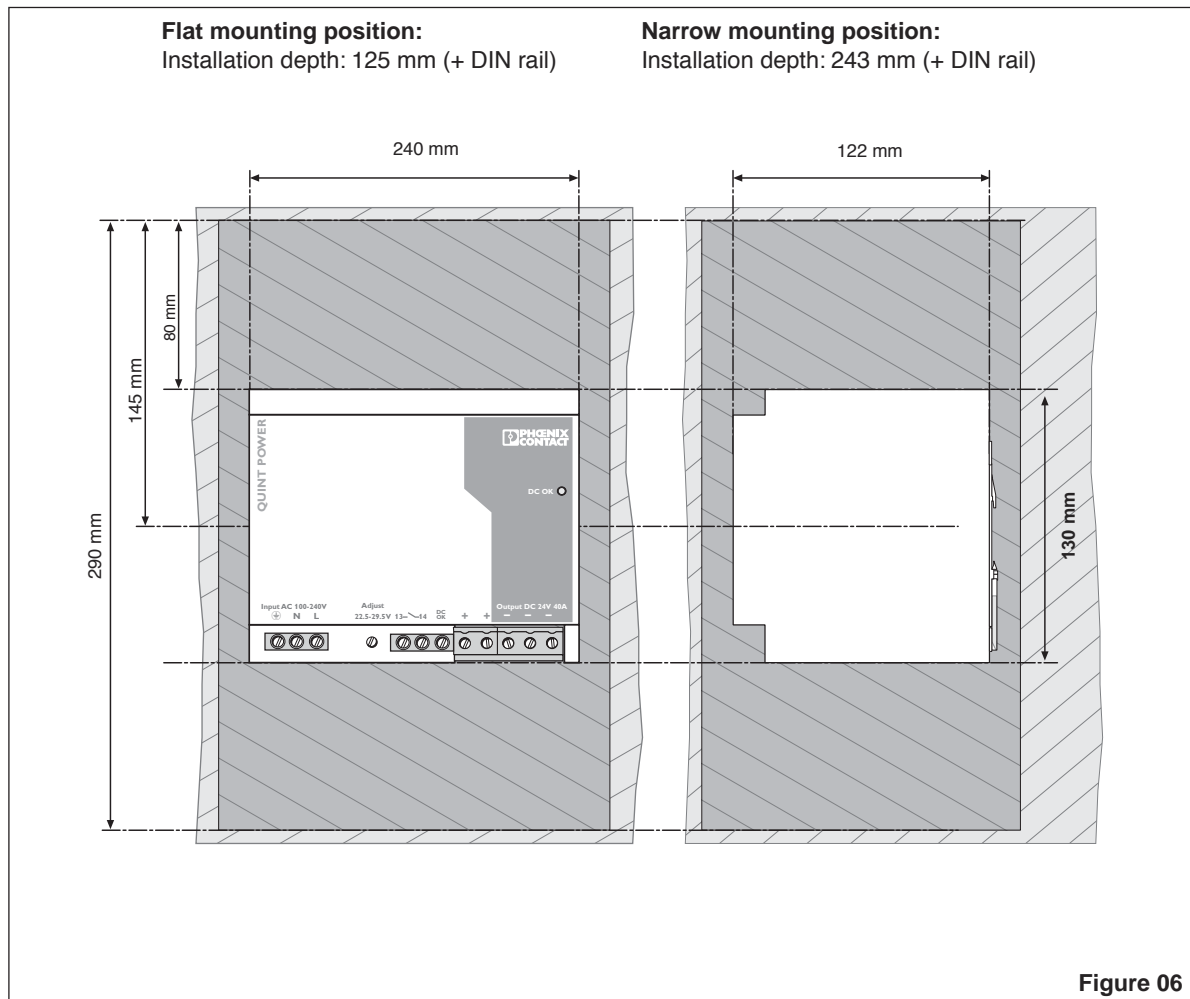

Figure 06

6.2. Flat Mounting Position

The device is supplied ready for installation in a flat mounting position.

Mounting:

Place the module with the DIN rail guideway on the **top edge** of the DIN rail and then snap it **downwards**.

Removal:

Release the snap-on catch using a screwdriver and then detach the module from the **bottom edge** of the DIN rail.

6.3. Narrow Mounting Position

A narrow mounting position can be achieved by mounting the module onto the DIN rail at a 90° angle. To do this, mount the DIN rail adapter (UTA 107) ⑦ as shown in Figure 08. No additional assembly material is required. Mounting screws: Torx T10 (torque 0.8 - 0.9 Nm).

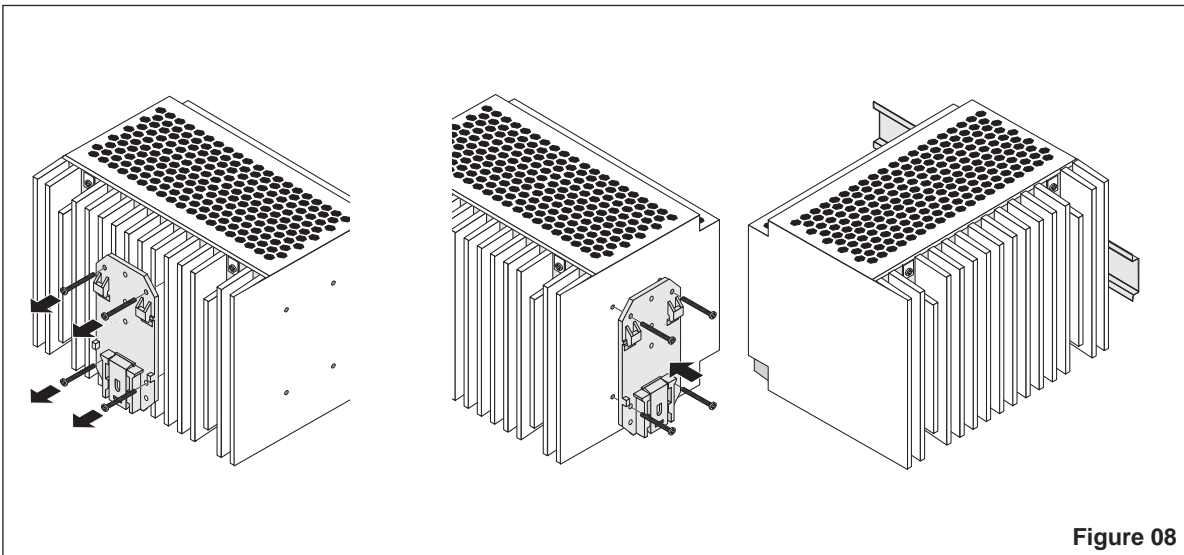
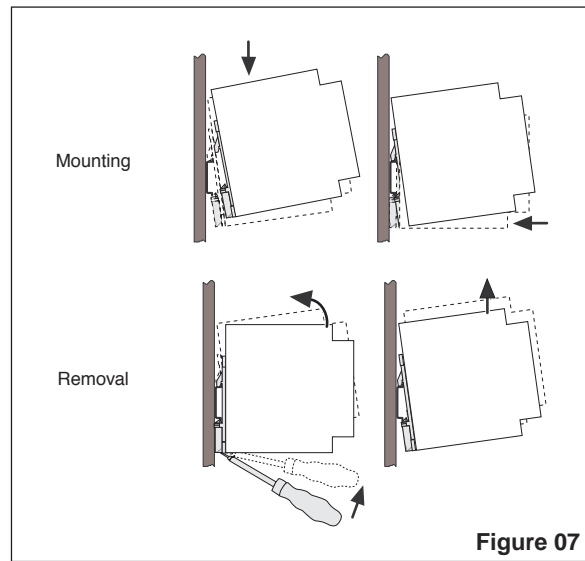

6.4. Connection of Various Types of Network: 100 - 240 V AC Networks

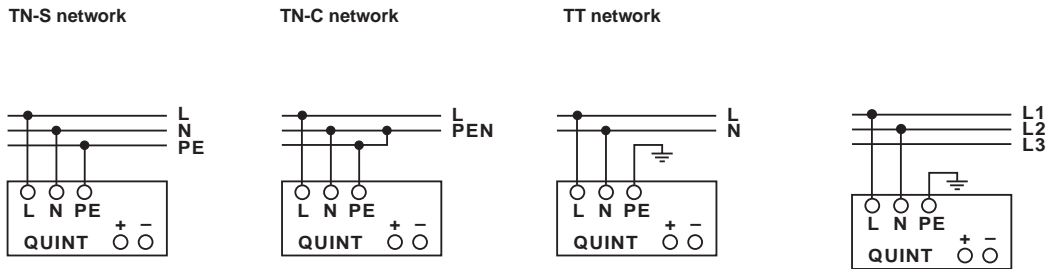

Figure 09

Connecting Cable:

To maintain UL approvals, use copper cables, which are designed for operating temperatures > +75°C.

The following cable cross sections can be connected:

	Solid [mm ²]	Stranded [mm ²]	AWG	Torque		Stripping Length
				[Nm]	[lb in]	[mm]
①	0.2 - 6	0.2 - 4	25 - 10	0.5 - 0.6	5 - 7	7
③ ④	0.2 - 6	0.2 - 4	25 - 10	0.5 - 0.6	5 - 7	8
②	0.5 - 16	0.5 - 10	20 - 6	1.2 - 1.5	15	10

To maintain EN 60950/UL 60950, flexible cables require appropriate ferrules.

For reliable and safe-to-touch connections: Strip 7 mm from the input connector ends, 8 mm from the signal connector ends, and 10 mm from the output connector ends.

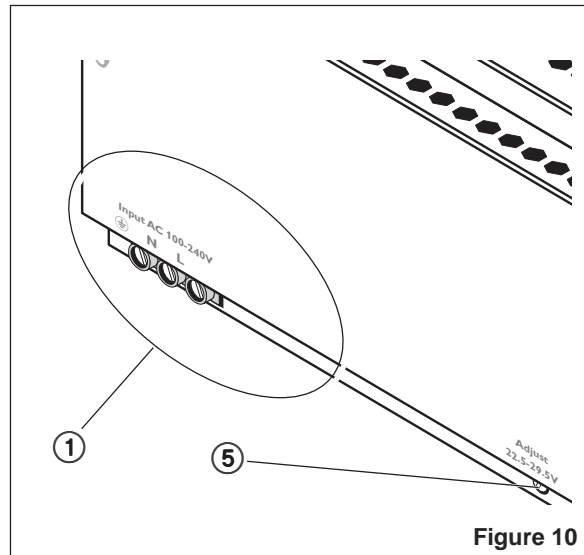
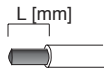

Figure 10

6.5. Input (①, Figure 10)

The 100 - 240 V AC connection is made using screw connections L, N, and Ⓧ. The device can be connected to single-phase AC networks or to two external conductors for three-phase networks (TN, TT or IT network according to VDE 0100 T300/IEC364-3) with nominal voltages of 100 - 240 V AC.

Protecting the Primary Side

The device must be installed according to the specifications of EN 60 950. It must be possible to switch off the device using a suitable disconnecting device outside the power supply.

Note that an all-pole disconnecting device must be provided for two-phase operation using two external conductors for a three-phase network. For this, mains protection on the primary side, for example, is suitable.

Further device protection is not required, as an internal fuse is present.

Recommended Fuse:

16 A or 25 A circuit breaker, characteristic B (or equivalent). A suitable fuse should be provided for DC applications.

If the internal fuse is blown, this is most probably due to a device fault. In this case, the device should be checked in the factory.

6.6. Output (Figure 11)

The 24 V DC connection is made using the "+" and "-" screw connections on the screw connection ②. The output voltage set upon delivery is 24 V DC.

The output voltage can be adjusted from 22.5 - 28.5 V DC on the potentiometer ⑤.

Protecting the Secondary Side:

The device is electronically short-circuit-proof and idling-proof. In the event of an error, the output voltage is limited to a maximum of 30 V DC.

It should be ensured that all output cables are the correct size for the maximum output current or have separate fuse protection.

The cable cross sections in the secondary circuit should be large enough to keep the voltage drops on the cables as low as possible.

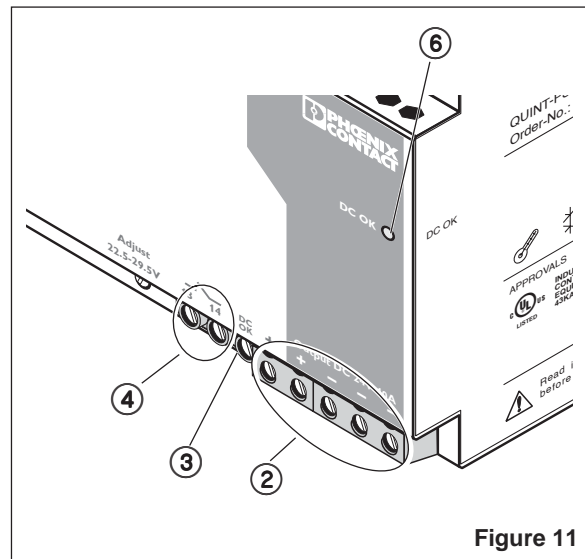

Figure 11

Signaling

Both DC OK outputs are used for preventive function monitoring of the power supply. A floating signal contact ④ and an active DC OK signal ③ are available. In addition, the DC OK LED ⑥ can be used to evaluate the function of the power supply directly at the installation location.

Floating Contact (Figure 12)

When opened, the floating signal contact indicates that the output voltage has fallen more than 10% below the set value. Signals and ohmic loads up to a maximum of 30 V and currents up to a maximum of 1 A can be switched.

With heavy inductive loads, e.g., a relay, a suitable protective circuit (e.g., free-wheeling diode) is required.

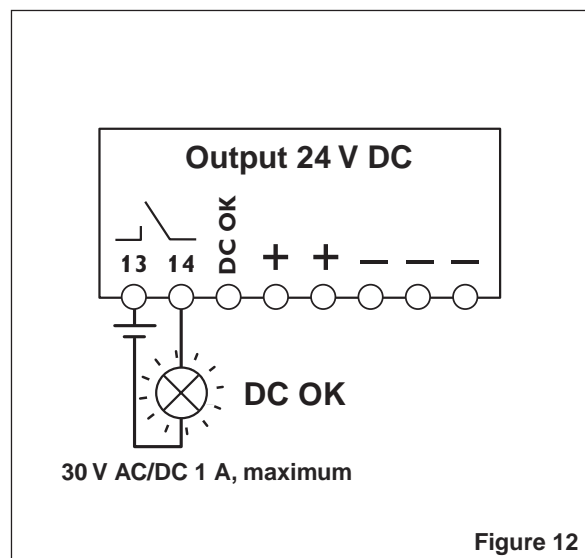

Figure 12

Active Signal Output (Figure 13)

The 24 V DC signal is between the "DC OK" and "-" connection terminal blocks and can be loaded with 20 mA maximum. This signal output indicates that the output voltage has fallen more than 10% below the set value when "active high" changes to "low".

The DC OK signal is isolated from the power output. This ensures that a separate supply does not enter from devices connected in parallel.

The 24 V DC signal can be connected directly to a logic input for evaluation.

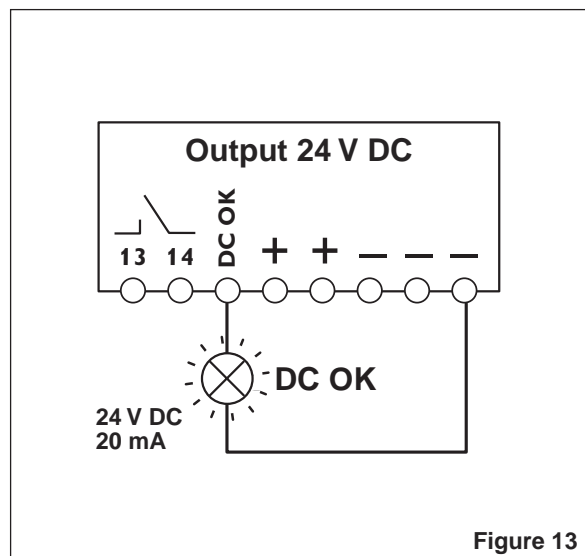

Figure 13

Signal Loop (Figure 14)

The two signal outputs mentioned above can be combined easily.

Example: Monitoring two devices

Use the active alarm output of device 1 and loop in the electrically isolated alarm output of device 2. In the event of an error, a group error message is generated. Any number of devices can be looped.

This signal combination saves on wiring costs and logic inputs.

DC OK LED

The green DC OK LED enables local function evaluation in the control cabinet.

LED ON	Normal operation of the power supply
LED flashing	The output voltage has fallen by more than 10%. There is a secondary load short circuit or overload.
LED OFF	No mains voltage is present or there is a device fault.

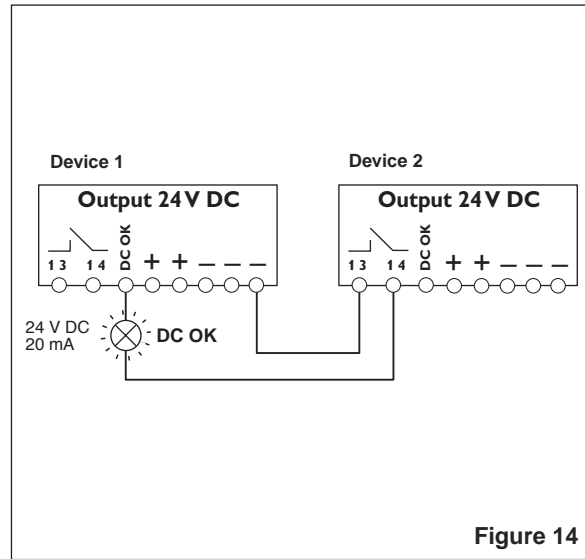

Figure 14

7. Function

7.1. Output Characteristic Curve

With heavy loads, the working point demonstrates the U/I characteristic curve shown in Figure 13. The output current is limited to 45 A.

The secondary voltage is reduced until the short circuit on the secondary side is removed.

The U/I characteristic curve ensures that both heavy capacitive loads and devices with DC/DC converters can be supplied by QUINT POWER in the input circuit without any problems.

Connected fuses are reliably tripped. The selectivity in your system configuration is ensured at all times.

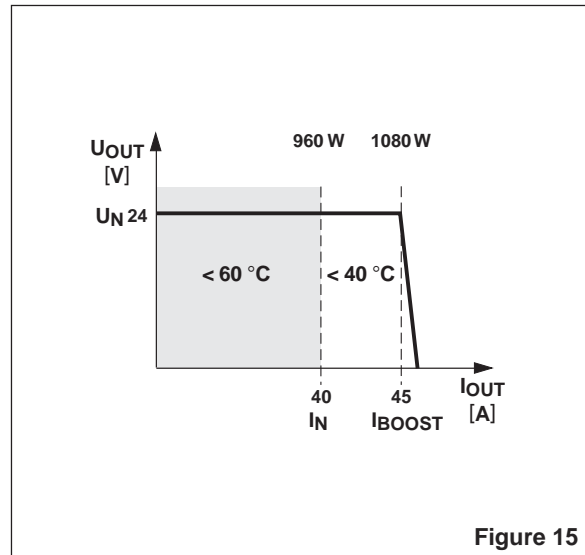

Figure 15

7.2. Temperature Response

The device can supply a nominal output current of 40 A up to an ambient operating temperature of +60°C.

The output power must be decreased by 2.5% per Kelvin temperature increase for ambient operating temperatures over +60°C.

At ambient operating temperatures above +70°C or in the event of a thermal overload, the device switches off. The device switches on again automatically once it has cooled down.

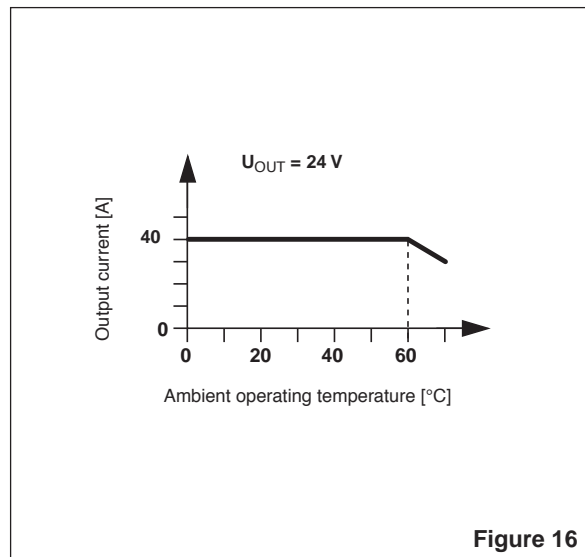

Figure 16

7.3. Parallel Operation

Devices of the same type can be connected in parallel to increase both redundancy and power. The default setting does not have to be adjusted.

If the output voltage is adjusted, an even current distribution can be ensured by precisely setting all power supply units that are operated in parallel to the same output voltage.

To ensure symmetrical current distribution we recommend that all cable connections from the power supply unit to the DIN rail are the same length and have the same cross section.

Depending on the system, for parallel connection of more than two power supply units a protective circuit should be installed at each individual device output (e.g., decoupling diode or DC fuse). This prevents high return currents in the event of a secondary device fault.

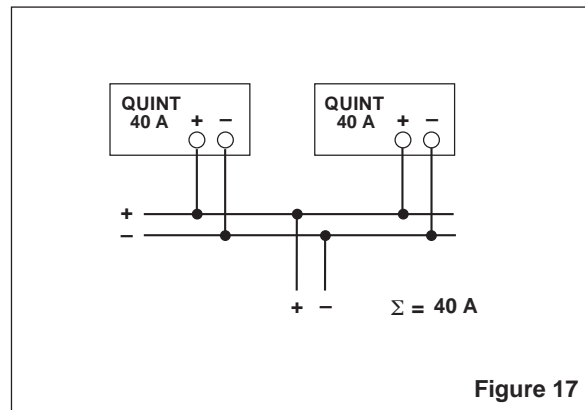

Figure 17

7.4. Redundancy Operation (Figure 17)

Redundant connections are designed for supplying systems, which place particularly high requirements on operational safety. If a fault occurs in the primary circuit of the first power supply unit, the second device automatically takes over the complete power supply without interruption, and vice versa.

For this purpose, the power supply units to be connected in parallel must be large enough that the total current requirements of all loads can be fully met by one power supply unit.

External decoupling diodes are required for 100% redundancy.

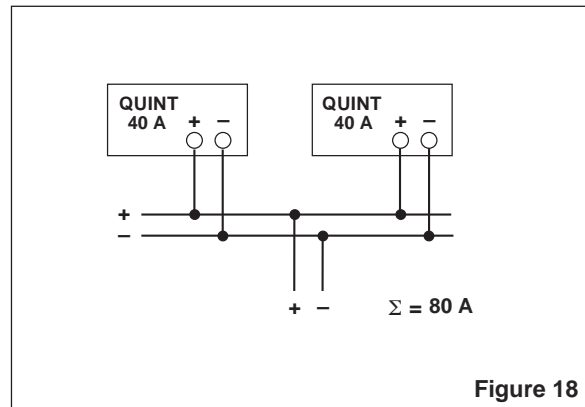

Figure 18

7.5. Power Increase (Figure 18)

The output current can be increased to $n \times I_N$ where n is the number of devices connected in parallel.

Parallel connection for increasing power is used when extending existing systems. A parallel connection is recommended if the power supply unit does not cover the current consumption of the most powerful load. Otherwise, the loads should be divided over independent individual devices.

A maximum of five devices can be connected in parallel.